

Fast-Set Plural-Component Equipment and Accessories

For Foam and Coatings Applications



PROVEN QUALITY. LEADING TECHNOLOGY.

Engineered for Performance

Expect superior foam and coatings results with Graco® Plural-Component Proportioners and Spray Guns



Complete systems for superior results

Whether you're spraying polyurethane foam insulation in a home, commercial building or rooftop, or applying polyurea to coat a bedliner or to protect any other substrate, Graco Plural-Component Proportioner Systems help you get the job done with superior results.

You'll discover that Graco equipment is easy to use, rugged, reliable and easy to maintain.

From entry-level models to high-output systems, there's a Graco Plural-Component Proportioning System that's ideal for your application.

Applications:

Polyurethane Foam

- Residential wall insulation
- Rim and band joist
- Roof insulation
- Aerospace
- Commercial walls

Coatings

- Concrete joint filling
- Marine and shipbuilding
- Potable water
- Wastewater treatment
- Truck bedliners
- Secondary containment
- Adhesives and caulk
- Waterproofing
- Tank and pipe coating
- Foundations

Build a complete system in just a few steps

1 SELECT A PROPORTIONER

Choose an air, electric or hydraulic model.

KEY FEATURES:

- Quick knockdown fluid sections
- Optional data reporting capabilities
- Foam models rated at 2000 psi (138 bar, 13.8 MPa)
- Coatings models rated up to 3500 psi (240 bar, 24.0 MPa)

2 SELECT HEATED HOSES

Choose from pressure ratings of 2000 psi or 3500 psi (138 to 240 bar, 13.8 to 24.0 MPa).
Choose 3/8 in or 1/2 in IDS.

3 SELECT HEATED WHIP HOSE

Choose from pressure ratings of 2000 psi or 3500 psi (138 to 240 bar, 13.8 to 24.0 MPa).
Choose 1/4 in or 3/8 in IDS.

4 SELECT A GUN

Choose an air-purge, mechanical-purge or liquid-purge gun with a round or flat pattern.

5 SELECT SUPPLY PROCESSING EQUIPMENT

5 SUPPLY PUMP

Choose from diaphragm or piston pumps for standard materials in drum-mount or wall-mount. Select a 2:1 piston pump for materials with higher viscosities.

6 AGITATOR KITS

Choose a kit to agitate your resin for a consistent coating. Graco's patented Twistork® agitators are very low shear to minimize material frothing.

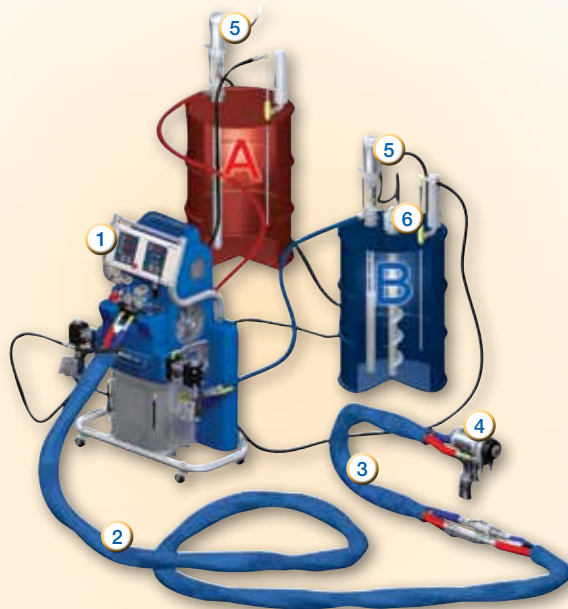

Air, Electric and Hydraulic Systems

No matter what the application, Graco has the solution



Which system is right for you?

AIR-DRIVEN

- Entry-level proportioning system
- Low-output applications
- Easy to use
- Minimal system feedback for operator



Reactor® A-20;
Guardian™ A-5, A-6

ELECTRIC

- The most popular proportioning system
- High value for great performance
- Mid- to high-output applications
- Provides operator with material data and system diagnostics for total control



Reactors E-10, E-20,
E-30, E-XP1, E-XP2

HYDRAULIC

- Top of the line system for high-production professionals
- Highest value for the greatest performance
- High-output applications
- Ideal for in-plant OEMs
- Provides superior, uninterrupted performance
- Provides operator with material data and system diagnostics for total control



Reactors H-25, H-40,
H-50, H-XP2, H-XP3

PERFORMANCE CHARTS

Use these charts to help identify the proportioner that will work most efficiently with each mix chamber. Flow rates are based on a material viscosity of 60 cps. See examples below.

HOW TO USE THESE GRAPHS

- Select spray pressure
- Select mix chamber or flow rate
- Choose proportioner model

Note: Darker shading includes proportioner models shown in lighter shaded areas.

FOAM EXAMPLE

Mix chamber: AR6060 (03)
Pressure: 1250 psi
Flow rate: 22 lb/min*
Proportioners H-25, E-30, H-40, H-50

COATING EXAMPLE

Mix chamber: AR2929 (00)
Pressure: 1500 psi
Flow rate: 0.9 gpm*
Proportioners A6, E-XP1, E-XP2, H-XP2, H-XP3

* Output of flat tip will be slightly less than round equivalent.

PROPORTIONERS FOR FOAM

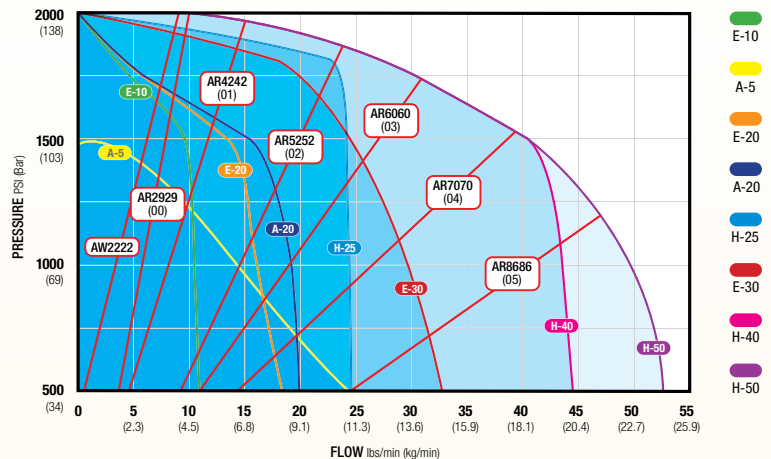

PROPORTIONERS FOR COATINGS

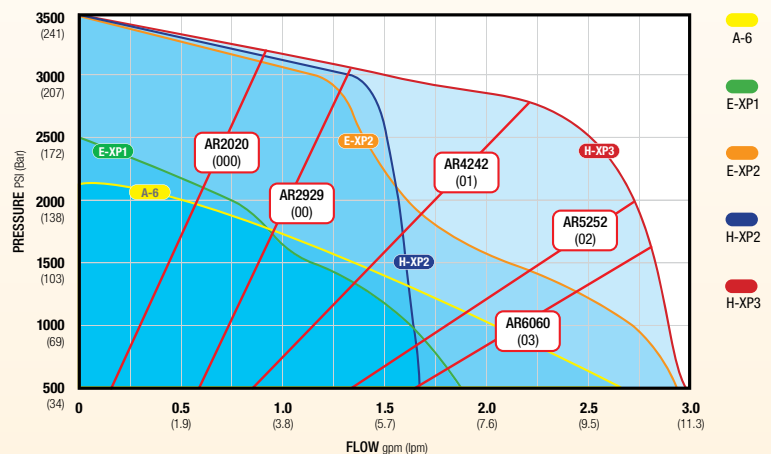

Electric Proportioners

Preferred choice for medium- to high-output foam or coatings applications

Reactor E-Series: High performance at an outstanding value

Equipped with material data and system diagnostics, Reactor E-Series proportioners provide total control. Advanced features provide longer equipment life, more uptime for your spray day and overall Graco reliability.

- Circulation valves with longer-lasting seals
- Heat transformers that don't require tap settings
- Longer-lasting modular heater control boards that minimize downtime
- Models include: E-10, E-20, E-30, E-XP1, E-XP2

Digital Heat and Pressure Controls

Allow you to precisely program temperatures and pressures, and monitor machine performance

Powerful Hybrid Heaters

Provide better temperature control

ISO Pump Lube System

Prevents isocyanate crystallization on the pump seal and shaft

Quick Knockdown Lower Pumps

For easy disassembly and maintenance

Rugged, Portable Design

Easy maneuverability around the jobsite



Electric Motor

Provides superior efficiency and performance

Circulation Valves

Reduce isocyanate crystallization while offering more controlled pressure balancing

Hose Control

Reliable and accurate hose connection system. Flexible fluid temperature sensor allows you to monitor and control temperature closer to the gun.

Heat Platform

Circuit board is divided into easy-to-replace modules that simplify troubleshooting and maintenance, maximizing spray time



COMPACT AND PORTABLE

◀ Reactor E-10

Get smaller jobs done fast without sacrificing performance. Graco's portable E-10 sprayers are ideal for plural-component spray, joint-fill jobs and touch-ups.

- Electric power is low draw and plugs into standard outlets
- Intuitive start, stop and digital temperature display with single knob operation
- Easy-to-service fluid section reduces maintenance and increases productivity
- Electric motor improves performance and reduces operating costs
- Heaters and hose give up to 2000 watts to pre-heat circulating material

Applications

Foam Insulation

- Rim joists
- Roof patching
- Prep work
- Window repair

Coatings

- Small industrial jobs
- Concrete joint filling and flooring applications
- Small tank spraying using cold spray polyurea
- Industrial maintenance
- Hybrid polyureas

Hydraulic Proportioners

Top of the line equipment for high-production professionals

Reactor H-Series: Superior power and performance

Graco's line of hydraulic Reactors brings increased yield and performance to high-output spraying. Hydraulic systems are the choice of spraying professionals who want to reap the benefits of the latest spraying technologies and add productivity to boost their bottom line.

- Adjustable pressure imbalance for tighter or looser ratio error detection
- Flexibility to change A or B pumps for fixed ratio application other than 1:1
- Models include: H-25, H-40, H-50, H-XP2, H-XP3 and H-VR

Digital Heat and Pressure Controls

Allow you to precisely program temperatures and pressures, and monitor machine performance

Circulation Valves

Reduce isocyanate crystallization while offering more controlled pressure balancing

Hose Control

Reliable and accurate hose connection system. Flexible fluid temperature sensor allows you to monitor and control temperature closer to the gun.

ISO Pump Lube System

Prevents isocyanate crystallization on the pump seal and shaft

Powerful Hybrid Heaters

Heat material quickly and maintain temperature set points – even when spraying at maximum flow rates

Horizontal Pumps

Positive displacement pumps are easy to service and provide smoother changeover for maintaining best spray pattern

Troubleshooting Y-Strainer

Analog temperature and pressure gauges are standard

Heat Platform

Circuit board is divided into easy-to-replace modules that simplify troubleshooting and maintenance, maximizing spray time



VARIABLE RATIO DISPENSING

◀ Reactor H-VR – Variable Ratio Hydraulic Proportioner

The Reactor H-VR is a variable ratio proportioner that combines proven Graco hydraulic Reactor technology with variable ratio capabilities.

- For applications that require a range or difference in volumetric ratio
- Infinitely adjustable volume ratio from 1:1 to 2.5:1
- Dispenses polyurethane foams and polyurea coatings
- Rated for 3500 psi max working pressure
- 15,300 watt heaters

Ordering Information

Gun and hose sold separately

256886 Reactor H-VR, 230-volt, 3-ph

256887 Reactor H-VR, 400-volt, 3-ph

Air-Driven Proportioners

Easy-to-use, entry-level systems for low-output applications

Air Motor Control

On/Off/Start pump controls – shuts the system down if it goes over pressure

Digital Temperature Control

Provides accurate temperatures for better material properties

Recirculation Manifold

A quick, easy way to balance system pressures

ISO Pump Lube System

Submerges the ISO pump in lubricant to extend pump life



Reactor A-20: Compact and cost-effective

Ideal for residential foam insulation projects, the Reactor A-20 is compact, portable and easy to move.

- Heats material quickly with 6,000 watts of heat
- Auto hose heat control – powers up to 310 feet of hose
- Automatic over-temperature shutdown
- Basic unit includes inlet strainers, ball valves, air filter/water separator and fluid temperature sensor for whip hose
- Easily adapts to different electrical supply voltages using supplied jumpers

Guardian A-Series: Economy without compromise

The Guardian A-Series is a high-performance dispensing system for polyurethane foam, adhesives, and elastomeric coatings. Its compact, portable design fits through standard doorways and is easy to maneuver on the jobsite.

Guardian A-5:

- 5-inch air motor
- Max fluid pressure: 1600 psi (110 bar, 11.0 MPa)
- Max output: 20 lb/min (9 kg/min)
- In-plant versions available

Guardian A-6:

- 6-inch air motor
- Max fluid pressure: 2200 psi (169 bar, 16.9 MPa)
- Max output: 2.0 gpm (7.6 lpm)
- In-plant versions available



Controller

Controls three independent heat zones – ISO, resin and hose heat

ISO Pump Lube System

Prevents isocyanate crystallization on the pump seal and pump shaft
(available as an accessory)

Modular Heaters

6,000 or 12,000 watt

Portable Design

Compact, easy to move

Transfer Pumps and Agitator Kits

Engineered for more output, better performance and great value

T1 AND T2 TRANSFER PUMP FAMILY ▼

| | Part Number | Ratio | Maximum output – continuous | Maximum output – intermittent | Maximum input air pressure | Maximum output fluid pressure | Maximum ambient temperature | Maximum fluid temperature | Weight | Dimensions | Manual Number |
|-----------|-------------|--------|-----------------------------|-------------------------------|----------------------------|-------------------------------|-----------------------------|---------------------------|----------------|--|---------------|
| T1 | 256200 | 2:1 | 2.5 gpm (9.5 lpm) | 4.0 gpm (15 lpm) | 180 psi (12 bar, 1.2 MPa) | 360 psi (25 bar, 2.5 MPa) | 120°F (50°C) | 190°F (88°C) | 18 lb (8.4 kg) | 51.5 in (130.8 cm) length; 2.6 in (66 mm) diameter (cap) | 312766 |
| T2 | 295616 | 2.25:1 | 5.0 gpm (19 lpm) | 7.5 gpm (28 lpm) | 180 psi (12 bar, 1.2 MPa) | 405 psi (28 bar, 2.8 MPa) | 120°F (50°C) | 190°F (88°C) | 21 lb (9.5 kg) | 54 in (137 cm) length; 3.5 in (89 mm) diameter (cap) | 311882 |

- The T2 design doubles the output – from 2.5 to 5.0 gpm – able to keep up with high-output proportioners
- The smaller T1 pump allows for lower 2:1 output, ideal for spraying applications
- Quick-disconnect feature allows easier drum removal and faster change-outs
- Improved fluid intake easily handles higher viscosity materials – even in cold conditions
- Reliable and cost-effective



Quick-release Bung Adapter

For easy drum removal without interference from hose connections

Corrosion-resistant Components

Stainless steel wetted parts

PTFE Seals

Improved performance for less maintenance



◀ TWISTORK HELIX MIXER

- Air-operated with a variable-speed, 1.5 HP motor, capable of 100 psi (7 bar, 0.7 MPa) maximum working pressure
- Available in carbon steel and stainless steel
- Built for long-life, corrosion-resistance and structural integrity
- Patented, helix-shaped mixing blades are threaded through a closed-head drum's standard bung opening
- Heavy-duty agitator features lube-free assembly, eliminating fluid contamination
- Gentle mixing reduces degradation and splashing, compared to propeller blades

Graco Proportioners for Foam and Coatings

Technical Specifications and Ordering Information



FOAM PROPORTIONERS

| | Air-Driven (A Series) | | Electric (E Series) | | | Hydraulic (H Series) |
|-----------------------------|--|---|---|--|--|---|
| MODEL ▶ | A-5 | A-20 | E-10 | E-20 | E-30 | H-25 |
| Max Working Pressure | 1600 psi (110 bar, 11.0 MPa) 24 scfm air consumption@100 psi | 2000 psi (138 bar, 13.8 MPa) 26 scfm air consumption@100 psi | 2000 psi (138 bar, 13.8 MPa) | 2000 psi (138 bar, 13.8 MPa) | 2000 psi (138 bar, 13.8 MPa) | 2000 psi (138 bar, 13.8 MPa) |
| Min Working Pressure | N/A | N/A | N/A | N/A | N/A | 850 psi (59 bar, 5.9 MPa) |
| Max Hose Length | 310 ft (94 m) | 210 ft (64 m) | 105 ft (32 m) | 210 ft (64 m) | 310 ft (94 m) | 310 ft (94 m) |
| Max Fluid Temp | 180°F (82°C) | 190°F (88°C) | 160°F (71°C) | 190°F (88°C) | 190°F (88°C) | 190°F (88°C) |
| Output | 20 lb (9 kg)/min | 20 lb (9 kg)/min | 12 lb (5.4 kg)/min | 20 lb (9 kg)/min | 30 lb (13.6 kg)/min | 22 lb (10 kg)/min |
| Weight | 248 lb (112 kg) | 250 lb (114 kg) | Heated: 160 lb (72 kg) Unheated: 150 lb (68 kg) | 342 lb (155 kg) | 400 lb (181 kg) | 8 kW: 535 lb (243 kg) 15 kW: 562 lb (255 kg) |
| Ordering Information | <p>With 6.0 kW heater:</p> <p>50A-220V, 1-ph GC1750 (Bare) GCA525 (P2 Pkg)</p> <p>20A-220V, 3-ph GC1752 (Bare) GCA535 (P2 Pkg)</p> <p>20A-380V, 3-ph GC1753 (Bare) GCA512 (P2 Pkg)</p> <p>With 12 kW heater:</p> <p>85A-220V, 1-ph GC1775 (Bare) GCA526 (P2 Pkg)</p> <p>35A-220V, 3-ph GC1776 (Bare) GCA536 (P2 Pkg)</p> <p>35A-380V, 3-ph GC1777 (Bare) GCA513 (P2 Pkg)</p> | <p>With 6.0 kW heater:</p> <p>40A-230V, 1-ph 253831 (Bare) AP3831 (AP Pkg) CS3831 (CS Pkg) P23831 (P2 Pkg)</p> <p>32A-230V, 3-ph 253831 (Bare) AP3831 (AP Pkg) CS3831 (CS Pkg) P23831 (P2 Pkg)</p> <p>18.5A-380V, 3-ph (4-wire) 253831 (Bare) AP3831 (AP Pkg) CS3831 (CS Pkg) P23831 (P2 Pkg)</p> | <p>With 1.7 kW heater:</p> <p>120V, 2-cord 249570 (Bare) AP9570 (AP Pkg) CS9570 (CS Pkg)</p> <p>With 2.0 kW heater:</p> <p>240V, 2-cord 249571 (Bare) AP9571 (AP Pkg) CS9571 (CS Pkg)</p> <p>240V, 1-cord 249572 (Bare) AP9572 (AP Pkg) CS9572 (CS Pkg)</p> <p>Unheated ambient system:</p> <p>120V 249576 (Bare) 249806 (Pkg)</p> <p>240V 249577 (Bare) 249808 (Pkg)</p> | <p>With 6.0 kW heater:</p> <p>48A-230V, 1-ph 259025 (Bare) AP9025 (AP Pkg) CS9025 (CS Pkg) P29025 (P2 Pkg)</p> <p>32A-230V, 3-ph 259034 (Bare) AP9034 (AP Pkg) CS9034 (CS Pkg) P29034 (P2 Pkg)</p> <p>24A-400V, 3-ph 259030 (Bare) AP9030 (AP Pkg) CS9030 (CS Pkg) P29030 (P2 Pkg)</p> | <p>With 10.2 kW heater:</p> <p>78A-230V, 1-ph 259026 (Bare) AP9026 (AP Pkg) CS9026 (CS Pkg) P29026 (P2 Pkg)</p> <p>50A-230V, 3-ph 259035 (Bare) AP9035 (AP Pkg) CS9035 (CS Pkg) P29035 (P2 Pkg)</p> <p>34A-400V, 3-ph 259031 (Bare) AP9031 (AP Pkg) CS9031 (CS Pkg) P29031 (P2 Pkg)</p> <p>With 15.3 kW heater:</p> <p>100A-230V, 1-ph 259057 (Bare) AP9057 (AP Pkg) CS9057 (CS Pkg) P29057 (P2 Pkg)</p> <p>62A-230V, 3-ph 259058 (Bare) AP9058 (AP Pkg) CS9058 (CS Pkg) P29058 (P2 Pkg)</p> <p>35A-400V, 3-ph 259059 (Bare) AP9059 (AP Pkg) CS9059 (CS Pkg) P29059 (P2 Pkg)</p> | <p>With 8.0 kW heater:</p> <p>69A-230V, 1-ph 255400 (Bare) AP5400 (AP Pkg) CS5400 (CS Pkg) P25400 (P2 Pkg)</p> <p>46A-230V, 3-ph 255401 (Bare) AP5401 (AP Pkg) CS5401 (CS Pkg) P25401 (P2 Pkg)</p> <p>35A-400V, 3-ph 255402 (Bare) AP5402 (AP Pkg) CS5402 (CS Pkg) P25402 (P2 Pkg)</p> <p>With 15.3 kW heater:</p> <p>100A-230V, 1-ph 255406 (Bare) AP5406 (AP Pkg) CS5406 (CS Pkg) P25406 (P2 Pkg)</p> <p>59A-230V, 3-ph 255407 (Bare) AP5407 (AP Pkg) CS5407 (CS Pkg) P25407 (P2 Pkg)</p> <p>35A-400V, 3-ph 255408 (Bare) AP5408 (AP Pkg) CS5408 (CS Pkg) P25408 (P2 Pkg)</p> |
| Operation manual | A5-6,000w = 313268 A5-12,000w = 313269 | 311511 | 311075 | 312065 | 312065 | 312062 |
| Repair manual | None | 311512 | 311075 | 312066 | 312066 | 312063 |

Packages include spray hose, whip hose and gun.



COATINGS PROPORTIONERS

| | | Air-Driven (A Series) | Electric (E Series) | | Hydraulic (H Series) | |
|---|---|---|---|---|---|--|
| H-40 | H-50 | A-6 | E-XP1 | E-XP2 | H-XP2 | H-XP3 |
| 2000 psi (138 bar, 13.8 MPa) | 1700 psi (117 bar, 11.7 MPa) 1-ph 2000 psi (138 bar, 13.8 MPa) 3-ph | 2200 psi (169 bar, 16.9 MPa) 33 scfm air consumption@100psi | 2500 psi (172 bar, 17.2 MPa) | 3500 psi (240 bar, 24.0 MPa) | 3500 psi (240 bar, 24.0 MPa) | 3-ph: 3500 psi (240 bar, 24.0 MPa) 1-ph: 3200 psi (221 bar, 22.1 MPa) |
| 600 psi (41 bar, 4.1 MPa) | 600 psi (41 bar, 4.1 MPa) | N/A | N/A | N/A | 1200 psi (83 bar, 8.3 MPa) | 850 psi (59 bar, 5.9 MPa) |
| 410 ft (125 m) | 410 ft (125 m) | 310 ft (94 m) | 210 ft (64 m) | 310 ft (94 m) | 310 ft (94 m) | 410 ft (125 m) |
| 190°F (88°C) | 190°F (88°C) | 180°F (82°C) | 190°F (88°C) | 190°F (88°C) | 190°F (88°C) | 190°F (88°C) |
| 45 lb (20 kg)/min | 52 lb (23.6 kg)/min | 2.0 gpm (7.6 lpm) | 1.0 gpm (3.8 lpm) | 2.0 gpm (7.6 lpm) | 1.5 gpm (5.7 lpm) | 2.8 gpm (10.6 lpm) |
| 597 lb (271 kg) | 597 lb (271 kg) | 254 lb (115 kg) | 342 lb (155 kg) | 438 lb (199 kg) | 562 lb (255 kg) | 597 lb (271 kg) |
| With 12.0 kW heater: 100A-230V, 1-ph 253400 (Bare) AP3400 (AP Pkg) P23400 (P2 Pkg) With 15.3 kW heater: 71A-230V, 3-ph 253401 (Bare) AP3401 (AP Pkg) P23401 (P2 Pkg) 41A-400V, 3-ph 253402 (Bare) AP3402 (AP Pkg) P23402 (P2 Pkg) With 20.4 kW heater: 95A-230V, 3-ph 253407 (Bare) AP3407 (AP Pkg) P23407 (P2 Pkg) 52A-400V, 3-ph 253408 (Bare) AP3408 (AP Pkg) P23408 (P2 Pkg) | With 12.0 kW heater: 100A-230V, 1-ph 253725 (Bare) AP3725 (AP Pkg) P23725 (P2 Pkg) With 15.3 kW heater: 71A-230V, 3-ph 253726 (Bare) AP3726 (AP Pkg) P23726 (P2 Pkg) 41A-400V, 3-ph 253727 (Bare) AP3727 (AP Pkg) P23727 (P2 Pkg) With 20.4 kW heater: 95A-230V, 3-ph 256505 (Bare) AP6505 (AP Pkg) P26505 (P2 Pkg) 52A-400V, 3-ph 256506 (Bare) AP6506 (AP Pkg) P26506 (P2 Pkg) | With 6.0 kW heater: 50A-220V, 1-ph GC1819 (Bare) GCA625 (P2 Pkg) 20A-220V, 3-ph GC1821 (Bare) GCA635 (P2 Pkg) 20A-380V, 3-ph GC1823 (Bare) GCA612 (P2 Pkg) With 12.0 kW heater: 85A-220V, 1-ph GC1825 (Bare) GCA626 (P2 Pkg) 35A-220V, 3-ph GC1827 (Bare) GCA636 (P2 Pkg) 35A-380V, 3-ph GC1829 (Bare) GCA613 (P2 Pkg) | With 10.2 kW heater: 69A-230V, 1-ph 259024 (Bare) AP9024 (AP Pkg) P29024 (P2 Pkg) 43A-230V 3-ph 259033 (Bare) AP9033 (AP Pkg) P29033 (P2 Pkg) 24A-400V, 3-ph 259029 (Bare) AP9029 (AP Pkg) P29029 (P2 Pkg) | With 15.3 kW heater: 100A-230V, 1-ph 259028 (Bare) AP9028 (AP Pkg) P29028 (P2 Pkg) 62A-230V, 3-ph 259036 (Bare) AP9036 (AP Pkg) P29036 (P2 Pkg) 35A-400V, 3-ph 259032 (Bare) AP9032 (AP Pkg) P29032 (P2 Pkg) | With 15.3 kW heater: 100A-230V, 1-ph 255403 (Bare) AP5403 (AP Pkg) P25403 (P2 Pkg) 59A-230V, 3-ph 255404 (Bare) AP5404 (AP Pkg) P25404 (P2 Pkg) 35A-400V, 3-ph 255405 (Bare) AP5405 (AP Pkg) P25405 (P2 Pkg) | With 12.0 kW heater: 100A-230V, 1-ph 253403 (Bare) AP3403 (AP Pkg) P23403 (P2 Pkg) With 20.4 kW heater: 95A-230V, 3-ph 253404 (Bare) AP3404 (AP Pkg) P23404 (P2 Pkg) 52A-400V, 3-ph 253405 (Bare) AP3405 (AP Pkg) P23405 (P2 Pkg) |
| 312062 | 312062 | A6 - 6000w = 313270 A6 - 12,000w = 313271 | 312065 | 312065 | 312062 | 312062 |
| 312063 | 312063 | None | 312066 | 312066 | 312063 | 312063 |

Packages include spray hose, whip hose and gun.

Liquid-Purge Guns

Unprecedented features that will change the way you spray

Fusion® CS with ClearShot™ Technology – A new class of spray gun

Graco's new Fusion CS plural-component spray gun with ClearShot (CS) Technology delivers improved productivity and performance throughout the spray day. The secret of the revolutionary ClearShot Technology is the ClearShot Liquid which is inserted into the gun's handle. Every time you pull the trigger, ClearShot Liquid is dispensed into the mix chamber and helps remove any built-up chemical – keeping it clean.

CLEARSHOT TECHNOLOGY

- ClearShot Liquid helps remove built-up material – virtually eliminating drilling of mix chamber
- Maximizes daily spraying uptime and annual productivity
- Maintains patterns and maximizes each kit with a clean mix chamber, saving time and money on material



Liquid-Purge

- Reduces purge air by 75%, minimizing material blowback
- Gain flexibility and maneuverability to spray in small, tight areas

Industry-First Quick-Change Front End

- Swap out fluid head in seconds
- Non-stick polymer cover for easy cleanup
- "Air knife" – reduces material buildup

Variable Flow Setting

- Switch from large to small spray patterns in seconds
- Ten different settings

New Manifold

- Easy on/off valves
- Check valves block fluid flow when manifold is disconnected
- Quick filter screen change-outs



New ClearShot Cartridge

Keeps gun mix chamber clear



Chromex™-Coated Side Seals and Mix Chamber

- More resistance to corrosion and wear
- Save time and money in replacements over the long-term

Screw-in-Place Side Seals

- Overall maintenance is quicker and simpler
- Fewer O-rings ensure better crossover protection and keep appropriate mix and proportions of material for better end results

Faster/Shorter Trigger Pull

- Responsive trigger delivers quick shots
- Diminishes operator fatigue

Air-Purge Guns

Plural-component spraying made easy

Fusion AP – Easy to use, easy to maintain

- Air-blast tip cleaning reduces build-up and tip clogging
- Hardened stainless steel mix chambers are built to last
- Longer life side seals reduce maintenance and let you spray a wider range of materials – choose from hardened stainless steel or PolyCarballoy options
- Advanced mix module and tip design improves mixing
- Solvent-resistant components and O-rings let you soak the whole gun without swelling or damage
- Daily maintenance in a matter of seconds with the quick-shot grease port
- Easy-to-use design makes maintenance quick and easy

GAP PRO GUN

- For construction, bedliners, roofing and other plural-component spraying
- Hardened steel side seals and mix chamber for long-lasting performance
- No adjustments necessary
- Easy access screens reduce end-of-the-day maintenance time



Quick-Release Fluid Housing

Easily change mix chambers without tools

Hand-Tightened Front Cap

Clean and maintain seals and mix chamber without tools

Cyclone-Mix™ Chamber

Hardened stainless steel construction for longer life

Durable Side Seals

Rugged stainless steel or PolyCarballoy construction for longer life

Check Valves with Screens

Cartridge design for easy maintenance

Ergonomic Handle

Smooth curved handle improves operator comfort and reduces fatigue

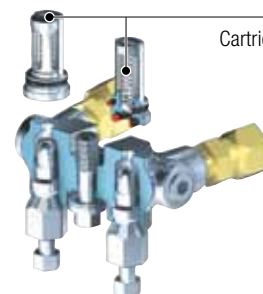
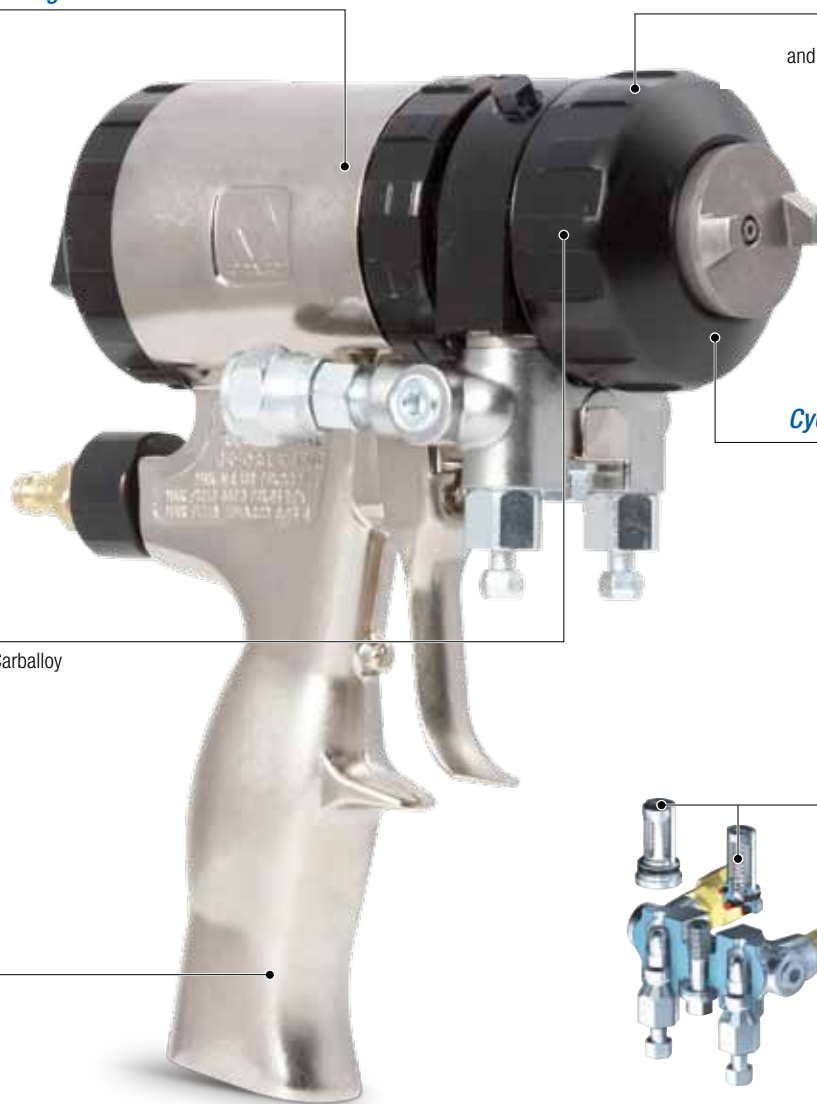

Air-Purge Guns

Plural-component spraying made easy

PROBLER® P2 – Compact and ergonomic

Recognized by the industry for its superior performance, the P2 gun's light, easy-to-handle design lets you spray and maneuver easily – even in difficult spraying positions. At the end of the day, maintenance is easy. No cleaning small air passages with tiny drill bits. The P2 has check valves that separate the liquid portion and dry side of the gun.

- Responsive trigger action – double piston design provides more than 300 pounds (136 kg) of triggering force
- The mix chamber insert can be replaced without replacing the entire chamber
- Anti-crossover design virtually eliminates possibility of material entering the air piston

P2 ELITE

- P2 model's side blocks offer alternate hose routing configurations
- Allows access to ISO and resin filters without removing side blocks
- Allows for use of additional accessories



Grease Fitting

For quick daily maintenance

Two-Piece Mix Chamber

Designed to reduce downtime

Powerful Dual Air Piston

- Provides strong trigger force
- Dramatically increases mix chamber pull-back pressure

Ergonomic Handle and Balanced Design

Comfortable, compact and lightweight



Mechanical-Purge Guns

Best material mix on the market

Fusion MP – Designed for superior mixing

- Handles from very low output, thin mil applications to large, high flow, high-output applications just by changing the mix module and tip
- Easy mechanical cleaning – mix modules and tips are cleaned with a drill bit
- Smoother finish and better atomization
- Offers more advanced features than all other mechanical-purge guns combined

LONG-LASTING MIX MODULES PROVIDE EXCELLENT MIXING

- Advanced mix module and tip design provides excellent mix and material properties
- PolyCarballoy mix modules for proven long life
- CeramTip™ is durable and easy to change
- Significantly reduces repair and maintenance costs

GX-7 GUN

- Excellent for polyurethane foams and elastomeric coatings
- Great mixing and pattern control with its unique internal impingement mixing design
- Designed to handle the toughest job-site conditions



Purge Rod

Easy-to-set, one piece rod for longer life

CeramTip

Durable and easy to change

Adjustable Front Packing

PolyCarballoy Mix Module

For proven long life

Ergonomic Handle

Smooth curved handle improves operator comfort and reduces fatigue

Check Valves with Screens

Cartridge design for easy maintenance



Graco Plural-Component Spray Guns

Technical Specifications



| | Liquid-Purge | | Air-Purge | |
|---|---|---|---|---|
| MODEL ▶ | FUSION CS | FUSION AP | P2 | GAP PRO |
| Materials sprayed | Foam and coatings | Foam and coatings | Foam and coatings | Foam and coatings |
| Maximum Output | 25 lb/min (11.3 kg/min) | 50 lb/min (22.7 kg/min) | 40 lb/min (18 kg/min) | 40 lb/min (18 kg/min) |
| Minimum Output | < 1 lb/min (<0.45 kg/min) | 3 lb/min (1.4 kg/min) | 3 lb/min (1.4 kg/min) | 3 lb/min (1.4 kg/min) |
| Maximum Fluid Working Pressure | 3500 psi (240 bar, 24.0 MPa) | 3500 psi (240 bar, 24.0 MPa) | 3200 psi (221 bar, 22.1 MPa) | 3000 psi (207 bar, 20.7 MPa) |
| Maximum Working Air Inlet Pressure | 130 psi (9 bar, 0.9 MPa) | 130 psi (9 bar, 0.9 MPa) | 110 psi (7.6 bar, 0.76 MPa) | 125 psi (8.6 bar, 0.86 MPa) |
| Maximum Fluid Temperature | 200°F (93°C) | 200°F (93°C) | 200°F (93°C) | 200°F (93°C) |
| Weight (with manifold) | 2.6 lb (1.2 kg) | 3.1 lb (1.4 kg) | 3.0 lb (1.4 kg) | 2.7 lb (1.2 kg) |
| Air inlet size | 1/4 npt quick disconnect nipple | 1/4 npt quick disconnect nipple | 1/4 npt | 1/4 npt quick disconnect nipple |
| A Component (ISO) inlet size | -5 JIC; 1/2-20 UNF swivel | -5 JIC; 1/2-20 UNF swivel | -5 JIC; 1/2-20 UNF swivel | -5 JIC; 1/2-20 UNF swivel |
| B Component (Resin) inlet size | -6 JIC; 9/16-18 UNF swivel | -6 JIC; 9/16-18 UNF swivel | -6 JIC; 9/16-18 UNF swivel | -6 JIC; 9/16-18 UNF swivel |
| Wetted Parts | Aluminum, stainless steel, plated carbon steel, brass, chemically resistant O-rings | Aluminum, stainless steel, plated carbon steel, brass, chemically resistant O-rings | Aluminum, stainless steel, plated carbon steel, brass, carbide, fluorocarbon O-rings | Aluminum, stainless steel, plated carbon steel, brass, carbide, fluorocarbon O-rings |
| Gun Dimensions | 6.5 x 8.1 x 3.6 in (16.5 x 20.6 x 9.1 cm) | 7.5 x 8.1 x 3.3 in (19 x 20.6 x 8.4 cm) | 6.9 x 8.7 x 3.5 in (17.5 x 22 x 8.9 cm) | 7 x 7 x 4.4 in (17.8 x 17.8 x 11.2 cm) |
| Instruction manual | 312666 | 309550 | 313213 | 311322 |
| Applications | Residential foam insulation, roofing, other polyurethane foams and polyurea | Residential foam insulation, roofing, concrete, waterproofing and other polyurethane foams and elastomeric coatings | Residential foam insulation, roofing, concrete, waterproofing and other polyurethane foams and elastomeric coatings | Residential foam insulation, roofing, concrete, waterproofing and other polyurethane foams and elastomeric coatings |





| Mechanical-Purge | | | | | |
|---|---|---|---|---|--|
| FUSION MP | GX-7 | GX-7 DI | GX-7-400 | GX-8 | D-GUN |
| Foam and coatings | Foam only | Coatings only | Coatings only | Coatings only | Foam only |
| 50 lb/min (22.7 kg/min) | 40 lb/min (18 kg/min) | 22 lb/min (10.0 kg/min) | 8 lb/min (3.6 kg/min) | 1.5 lb/min (0.7 kg/min) | 16 lb/min (7.2 kg/min) |
| 2 lb/min (0.9 kg/min) | 3.5 lb/min (1.6 kg/min) | 4 lb/min (1.8 kg/min) | 3.5 lb/min (1.6 kg/min) | < 1 lb/min (0.45 kg/min) | 2 lb/min (1 kg/min) |
| 3500 psi (240 bar, 24.0 MPa) | 3500 psi (240 bar, 24.0 MPa) | 3500 psi (240 bar, 24.0 MPa) | 3500 psi (240 bar, 24.0 MPa) | 3500 psi (240 bar, 24.0 MPa) | 1000 psi (69 bar, 6.9 MPa) |
| 130 psi (9 bar, 0.9 MPa) | 125 psi (8.6 bar, 0.86 MPa) | 125 psi (8.6 bar, 0.86 MPa) | 125 psi (8.6 bar, 0.86 MPa) | 125 psi (8.6 bar, 0.86 MPa) | 110 psi (7.6 bar, 0.76 MPa) |
| 200°F (93°C) | 200°F (93°C) | 200°F (93°C) | 200°F (93°C) | 200°F (93°C) | 150°F (65°C) |
| 3.4 lb (1.5 kg) | 4.1 lb (1.9 kg) | 4.1 lb (1.9 kg) | 4.1 lb (1.9 kg) | 3.1 lb (1.4 kg) | 3.1 lb (1.4 kg) |
| 1/4 npt quick disconnect nipple | 1/4 npt quick disconnect nipple | 1/4 npt quick disconnect nipple | 1/4 npt quick disconnect nipple | 1/4 npt quick disconnect nipple | 1/8 npt quick disconnect nipple |
| -5 JIC; 1/2-20 UNF swivel | -5 JIC; 1/2-20 UNF swivel | -5 JIC; 1/2-20 UNF swivel | -5 JIC; 1/2-20 UNF swivel | -5 JIC; 1/2-20 UNF swivel | -5 JIC; 1/2-20 UNF swivel |
| -6 JIC; 9/16-18 UNF swivel | -6 JIC; 9/16-18 UNF swivel | -6 JIC; 9/16-18 UNF swivel | -6 JIC; 9/16-18 UNF swivel | -6 JIC; 9/16-18 UNF swivel | -6 JIC; 9/16-18 UNF swivel |
| Aluminum, stainless steel, plated carbon steel, brass, polycarbally, chemically resistant O-rings | Aluminum, stainless steel, brass, plated carbon steel, fluorocarbon O-rings | Aluminum, stainless steel, brass, plated carbon steel, fluorocarbon O-rings | Aluminum, stainless steel, brass, plated carbon steel, fluorocarbon O-rings | Aluminum, stainless steel, brass, plated carbon steel, fluorocarbon O-rings | Aluminum, stainless steel, plated carbon steel, brass |
| 7.6 x 8.1 x 3.1 in (19.3 x 20.6 x 7.9 cm) | 9 x 9.5 x 4.5 in (22.9 x 24.1 x 11.4 cm) | 9 x 9.5 x 4.5 in (22.9 x 24.1 x 11.4 cm) | 9 x 9.5 x 4.5 in (22.9 x 24.1 x 11.4 cm) | 7 x 7.5 x 2.5 in (17.8 x 19 x 6.4 cm) | 8 x 9 x 2.25 in (20.3 x 22.9 x 5.7 cm) |
| 309856 | 311321 | 311321 | 311321 | 311338 | 311320 |
| Residential foam insulation, roofing, concrete, waterproofing and other polyurethane foams and elastomeric coatings | Residential foam insulation, roofing, concrete and other polyurethane foams | Medium output fast-set polyurea, polyurethane and hybrid coatings | Low output fast-set polyurea, polyurethane and hybrid coatings | Very low output, fast-set polyurea, polyurethane and hybrid coatings | Low to medium output foam applications |

Gun Accessories

Choosing the correct mix chambers, modules and tips

Choosing the right tips and mix chambers

1. Choose a Round or Flat pattern for your tip or mix chamber
(typically round for foam and flat for coatings)
2. Specify "A" and "B" size for your orifice or chamber
3. Specify the desired tip size for your application

LEGEND

Fusion CS:

- RD = Round Mix Chamber
- WD = Wide Mix Chamber
- FL = Flat Mix Chamber
- FT = Flat Tip

Fusion AP:

- AR = Air (purge) Round Mix Chamber
- AF = Air (purge) Flat Mix Chamber
- AW = Air Wide Round Mix Chamber
- FT = Flat Tip (air-purge)

Fusion MP:

- MR = Mechanical (purge) Round
- XR = Direct Impinge Round
- RTM = Round Tip Mechanical (purge)
- MF = Mechanical (Purge) Flat
- XF = Direct Impinge Flat
- FTM = Flat Tip Mechanical (purge)

CHAMBER/ORIFICE CONVERSION

Use this conversion chart to convert the Chamber size to the Orifice size.

| Chamber Size | Orifice Size |
|--------------|--------------|
| 000 | .020 |
| 00 | .029 |
| 01 | .042 |
| 02 | .052 |
| 03 | .060 |
| 04 | .070 |
| 05 | .086 |

| Gun | Mix Chamber/Tip | Pattern at 24 in (61 cm) from target | Polyurea in GPM @ 2000 psi | Foam in lb/min @ 1000 psi | |
|------------------------------------|-----------------|--------------------------------------|----------------------------|---------------------------|------------|
| Fusion CS Round | | | | | |
| | | x in (x mm) | x gpm | x lb/min | |
| | CS20RD | RD2020 | 5 in (127 mm) | 0.5 gpm | 3 lb/min |
| | CS00RD | RD0000 | 8 in (203 mm) | 1.1 gpm | 7 lb/min |
| | CS01RD | RD0101 | 11 in (279 mm) | 1.6 gpm | 9 lb/min |
| | CS02RD | RD0202 | 12 in (305 mm) | 2.4 gpm | 14 lb/min |
| | CS03RD | RD0303 | 14 in (356 mm) | NA | 19 lb/min |
| Fusion CS Wide Round | | | | | |
| | CS22WD | WD2222 | 8 in (203 mm) | 0.5 gpm | 4.5 lb/min |
| | CS00WD | WD0000 | 15 in (381 mm) | 1.1 gpm | 7 lb/min |
| | CS01WD | WD0101 | 16 in (406 mm) | 1.6 gpm | 9 lb/min |
| | CS02WD | WD0202 | 18 in (457 mm) | 2.4 gpm | 14 lb/min |
| | CS03WD | WD0303 | 18 in (457 mm) | NA | 19 lb/min |
| Fusion CS Flat | | | | | |
| | CS20F1 | FL2020 w/FT0424 | 10 in (254 mm) | 0.5 gpm | 3 lb/min |
| | CS20F2 | FL2020 w/FT0438 | 10 in (254 mm) | 0.6 gpm | 3 lb/min |
| | CS00F1 | FL0000 w/FT0424 | 10 in (254 mm) | 1.0 gpm | 6 lb/min |
| | CS00F2 | FL0000 w/FT0438 | 10 in (254 mm) | 1.2 gpm | 7 lb/min |
| | CS00F3 | FL0000 w/FT0624 | 14 in (356 mm) | 1.0 gpm | 6 lb/min |
| | CS00F4 | FL0000 w/FT0638 | 14 in (356 mm) | 1.2 gpm | 7 lb/min |
| | CS00F5 | FL0000 w/FT0838 | 18 in (457 mm) | 1.2 gpm | 7 lb/min |
| | CS00F6 | FL0000 w/FT0848 | 18 in (457 mm) | 1.2 gpm | 7 lb/min |
| | CS01F1 | FL0101 w/FT0424 | 10 in (254 mm) | 1.0 gpm | 6 lb/min |
| | CS01F2 | FL0101 w/FT0438 | 10 in (254 mm) | 1.3 gpm | 9 lb/min |
| | CS01F3 | FL0101 w/FT0624 | 14 in (356 mm) | 1.0 gpm | 6 lb/min |
| | CS01F4 | FL0101 w/FT0638 | 14 in (356 mm) | 1.3 gpm | 9 lb/min |
| | CS01F5 | FL0101 w/FT0838 | 18 in (457 mm) | 1.3 gpm | 9 lb/min |
| | CS01F6 | FL0101 w/FT0848 | 18 in (457 mm) | 1.3 gpm | 9 lb/min |
| | CS02F1 | FL0202 w/FT0424 | 10 in (254 mm) | 1.0 gpm | 6 lb/min |
| | CS02F2 | FL0202 w/FT0438 | 10 in (254 mm) | 1.3 gpm | 9 lb/min |
| | CS02F3 | FL0202 w/FT0624 | 14 in (356 mm) | 1.0 gpm | 6 lb/min |
| | CS02F4 | FL0202 w/FT0638 | 14 in (356 mm) | 1.3 gpm | 9 lb/min |
| | CS02F5 | FL0202 w/FT0838 | 18 in (457 mm) | 1.3 gpm | 9 lb/min |
| | CS02F6 | FL0202 w/FT0848 | 18 in (457 mm) | 1.8 gpm | 12 lb/min |
| Fusion Air-Purge Round | | | | | |
| | 246099 | AR2020 | 5 in (127 mm) | 0.5 gpm | 3 lb/min |
| | 246100 | AR2929 | 8 in (203 mm) | 1.1 gpm | 7 lb/min |
| | 248617 | AR3737 | 9 in (227 mm) | 1.3 gpm | 8 lb/min |
| | 246101 | AR4242 | 11 in (279 mm) | 1.6 gpm | 9 lb/min |
| | 246102 | AR5252 | 12 in (305 mm) | 2.4 gpm | 14 lb/min |
| | 246103 | AR6060 | 14 in (356 mm) | NA | 19 lb/min |
| | 246104 | AR7070 | 15 in (381 mm) | NA | 25 lb/min |
| | 246105 | AR8686 | 18 in (457 mm) | NA | 35 lb/min |
| Fusion Air-Purge Wide Round | | | | | |
| | 24D581 | AW2828 | 15 in (381 mm) | 1.1 gpm | 7 lb/min |
| | NA | AW3333 | 15 in (381 mm) | 1.3 gpm | 8 lb/min |
| | 249529 | AW3939 | 16 in (406 mm) | 1.6 gpm | 9 lb/min |
| | 249530 | AW4646 | 18 in (457 mm) | 2.4 gpm | 14 lb/min |
| | NA | AW5757 | 18 in (457 mm) | NA | 19 lb/min |
| | NA | AW6464 | 22 in (564 mm) | NA | 25 lb/min |
| | NA | AW8282 | 24 in (610 mm) | NA | 35 lb/min |

| Gun | Mix Chamber/Tip | Pattern at 24 in (61 cm) from target | Polyurea in GPM @ 2000 psi | Foam in lb/min @ 1000 psi |
|--------------------------------------|--------------------------|--------------------------------------|----------------------------|---------------------------|
| Fusion Air-Purge Flat | | | | |
| 247101 | AF2020 (FT0424) | 10 in (254 mm) | 0.6 gpm | 3 lb/min |
| 247112 | AF2929 (FT0438) | 10 in (254 mm) | 1.2 gpm | 7 lb/min |
| 247124 | AF4242 (FT0638) | 14 in (356 mm) | 1.3 gpm | 9 lb/min |
| 247138 | AF5252 (FT0848) | 18 in (457 mm) | 1.8 gpm | 12 lb/min |
| Fusion Mechanical-Purge Round | | | | |
| 247003 | XR2323 (RTM030) | 6 in (152 mm) | 0.5 gpm | 4 lb/min |
| 247007 | XR2929 (RTM040) | 8 in (203 mm) | 0.9 gpm | 7 lb/min |
| 247212 / 247012 | MR3535 / XR3535 (RTM040) | 8 in (203 mm) | 1.2 gpm | 8 lb/min |
| 247219 / 247019 | MR4747 / XR4747 (RTM055) | 9 in (227 mm) | 1.7 gpm | 10 lb/min |
| 247226 / 247026 | MR5757 / XR5757 (RTM070) | 10 in (254 mm) | 2.7 gpm | 15 lb/min |
| 247232 | MR6666 (RTM080) | 11 in (279 mm) | NA | 24 lb/min |
| 247239 | MR8282 (RTM090) | 12 in (305 mm) | NA | 30 lb/min |
| 247246 | MR9494 (RTM110) | 12 in (305 mm) | NA | 39 lb/min |
| Fusion Mechanical-Purge Flat | | | | |
| 247051 | XF1313 (FTM424) | 10 in (254 mm) | 0.15 gpm | 1.5 lb/min |
| 247258 / 247058 | MF1818 / XF1818 (FTM424) | 10 in (254 mm) | 0.3 gpm | 2 lb/min |
| 247061 | XF 2323 (FTM424) | 10 in (254 mm) | 0.4 gpm | 2.5 lb/min |
| 247265 / 247065 | MF2929 / XF2929 (FTM424) | 10 in (254 mm) | 0.6 gpm | 3 lb/min |
| 247275 / 247075 | MF3535 / XF3535 (FTM638) | 14 in (356 mm) | 0.9 gpm | 6 lb/min |
| 247282 / 247082 | MF4747 / XF4747 (FTM638) | 14 in (356 mm) | 1.1 gpm | 7 lb/min |
| 247289 / 247089 | MF5757 / XF5757 (FTM638) | 14 in (356 mm) | 1.3 gpm | 8 lb/min |
| P2 Gun | | | | |
| GCP2RA | GC250A w/GC251A | 5 in (127 mm) | 0.4 gpm | 3 lb/min |
| GCP2R0 | GC2500 w/GC2510 | 9 in (229 mm) | 1.1 gpm | 8 lb/min |
| GCP2R1 | GC2501 w/GC2511 | 10 in (254 mm) | 1.6 gpm | 12 lb/min |
| GCP2R2 | GC2502 w/ GC2512 | 12 in (305 mm) | 2.5 gpm | 16 lb/min |
| GCP2R3 | GC2503 w/ GC2513 | 14 in (356 mm) | NA | 24 lb/min |
| GCP2R4 | GC2504 w/ GC2514 | 15.5 in (394 mm) | NA | 29 lb/min |
| GCP2R5 | GC2505 w/ GC2515 | 18 in (457 mm) | NA | 36 lb/min |
| P2 Elite Gun | | | | |
| GCP3RA | GC250A w/GC251A | 5 in (127 mm) | 0.4 gpm | 3 lb/min |
| GCP3R0 | GC2500 w/GC2510 | 9 in (229 mm) | 1.1 gpm | 8 lb/min |
| GCP3R1 | GC2501 w/GC2511 | 10 in (254 mm) | 1.6 gpm | 12 lb/min |
| GCP3R2 | GC2502 w/ GC2512 | 12 in (305 mm) | 2.5 gpm | 16 lb/min |
| GCP3R3 | GC2503 w/ GC2513 | 14 in (356 mm) | NA | 24 lb/min |
| GCP3R4 | GC2504 w/ GC2514 | 15.5 in (394 mm) | NA | 29 lb/min |
| GCP3R5 | GC2505 w/ GC2515 | 18 in (457 mm) | NA | 36 lb/min |
| P2 Auto Gun | | | | |
| GCP4RA | GC250A w/GC251A | 5 in (127 mm) | 0.4 gpm | 3 lb/min |
| GCP4R0 | GC2500 w/GC2510 | 9 in (229 mm) | 1.1 gpm | 8 lb/min |
| GCP4R1 | GC2501 w/GC2511 | 10 in (254 mm) | 1.6 gpm | 12 lb/min |
| GCP4R2 | GC2502 w/ GC2512 | 12 in (305 mm) | 2.5 gpm | 16 lb/min |
| GCP4R3 | GC2503 w/ GC2513 | 14 in (356 mm) | NA | 24 lb/min |
| GCP4R4 | GC2504 w/ GC2514 | 15.5 in (394 mm) | NA | 29 lb/min |
| GCP4R5 | GC2505 w/ GC2515 | 18 in (457 mm) | NA | 36 lb/min |

PART NUMBER EXAMPLES

FT0438

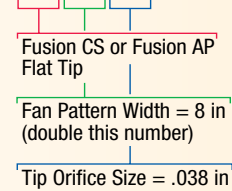

RD0202

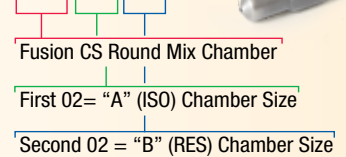

AF4242

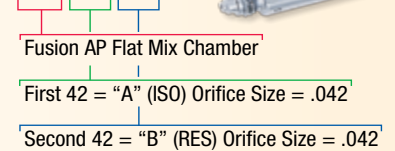

FTM424

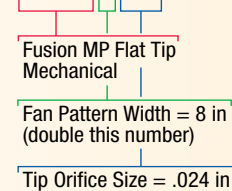

RTM030

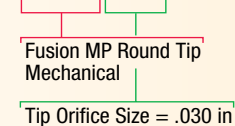

MR 2929

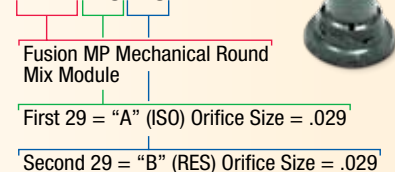

Ordering Information

To get genuine Graco accessories, see your nearest Graco distributor, or call Graco at 877-844-7226

Proportioner Accessories



| | |
|--------|--|
| 15B593 | Membrane switch shield |
| 15B742 | Wire harness extension for display, 50 ft (15 m) |
| 248921 | Heated hose controller, 2700 watt, allows Reactor heated hose extended past 300 ft (91 m). Requires 200-230 volts at 15 amps |
| 15F028 | Band heater, 1000 watt, for 55 gal drum, 230 volt |
| 206995 | TSL, 1 qt (0.95 l) |
| 206996 | TSL, 1 gal (3.8 l) |
| 246085 | Data reporting kit |
| 247827 | Heater control module |
| 247828 | A, B hose heater power module |
| 247838 | Modular heater control to retrofit electric/hydraulic units |
| 249634 | Cold spray kit – includes Ultra-Lite gun and restrictor valve. For Reactor E-10 models only. |
| 249635 | Joint fill kit – includes Ultra-Lite gun and extension tip. For Reactor E-10 models only. |
| 255148 | Circulation valve kit – includes ISO and resin circulation valves |
| 255149 | Circulation valve – ISO only |
| 255150 | Circulation valve – resin only |
| 256396 | Reactor conversion kit 1-ph to 3-ph, 230V |
| 256397 | Reactor conversion kit 3-ph to 1-ph, 230V |
| GC1845 | ISO Pump Lube System kit (<i>Guardian models only</i>) |
| 261669 | Fluid temperature sensor |

Heated Hoses



Hoses, 2000 psi (138 bar, 13.8 MPa)

| | |
|--------|--|
| 246045 | 1/4 in x 50 ft (6.3 mm x 15 m) |
| 246046 | 3/8 in x 50 ft (9.5 mm x 15 m) |
| 246047 | 1/2 in x 50 ft (12.7 mm x 15 m) |
| 246048 | 1/4 in x 25 ft (6.3 mm x 7.6 m) |
| 246049 | 3/8 in x 25 ft (9.5 mm x 7.6 m) |
| 246074 | 1/4 in x 50 ft (6.3 mm x 15 m), no thermocouple wire |
| 246075 | 3/8 in x 50 ft (9.5 mm x 15 m), no thermocouple wire |
| 246076 | 1/2 in x 50 ft (12.7 mm x 15 m), no thermocouple wire |
| 246678 | 3/8 in x 50 ft (9.5 mm x 15 m), with Scuffguard™ |
| 246050 | Whip hose: 1/4 in x 10 ft (6.3 mm x 3 m) with Scuffguard |
| 249586 | Whip hose: 1/4 in x 3 ft (6.3 mm x 91 cm) with Scuffguard |
| 255089 | 1/4 in x 3/8 in x 50 ft (6.3 mm x 9.5 mm x 15 m) with Scuffguard |
| 256407 | Unheated whip hose, 6 ft (1.8 m) |
| 256549 | 3/8 in x 50 ft (9.5 mm x 15 m) no thermocouple wire, with Scuffguard |

Hoses, 3500 psi (240 bar, 24.0 MPa)

| | |
|--------|--|
| 246052 | 1/4 in x 50 ft (6.3 mm x 15 m) |
| 246053 | 3/8 in x 50 ft (9.5 mm x 15 m) |
| 246054 | 1/2 in x 50 ft (12.7 mm x 15 m) |
| 246679 | 3/8 in x 50 ft (9.5 mm x 15 m), with Scuffguard |
| 246055 | Whip hose: 1/4 in x 10 ft (6.3 mm x 3 m), with Scuffguard |
| 246056 | Whip hose: 3/8 in x 10 ft (9.5 mm x 3 m), with Scuffguard |
| 249588 | 3/8 in x 50 ft (9.5 mm x 15 m) no thermocouple wire |
| 256548 | 1/2 in x 50 ft (12.7 mm x 15 m) with Scuffguard |
| 261335 | 1/2 in x 50 ft (12.7 mm x 15 m) no thermocouple wire |
| 247164 | 1/4 in x 3/8 in x 50 ft (6.3 mm x 9.5 mm x 15 m) with Scuffguard |
| 261336 | 3/8 in x 1/2 in x 50 ft (9.5 mm x 12.7 mm x 15 m) |
| 256626 | Unheated whip hose, 6 ft (1.8 m) |

Hose Accessories

| | |
|--------|---|
| 246077 | 10 ft (3 m) braided polyester mesh Scuffguard |
| 246078 | 50 ft (15 m) braided polyester mesh Scuffguard |
| 246456 | 50 ft (15 m) polyethylene Scuffguard |
| 246805 | 25 ft (7.6 m) braided polyester mesh Scuffguard |
| 15B296 | 50 ft (15 m) Fluid Temperature Sensor (FTS) cable |
| 15C626 | 25 ft (7.6 m) Fluid Temperature Sensor (FTS) cable |
| 261669 | Fluid temperature sensor |
| 261821 | Power-lock™ splice kit |
| 15M312 | Power-lock splice kit (20-pk) (enough for 10 hoses) |

Supply Pumps and Agitators



Complete Supply Pump Systems

Includes the following: All air and fluid fittings, hoses for two pumps.

| | |
|--------|--|
| 247955 | Complete T1 (247956) supply pump system |
| 246081 | Complete T2 (246898) supply pump system |
| 246655 | Complete Triton® 308 (246677) supply pump system |
| 246369 | Complete Husky™ 515 (246481) supply pump system |
| 246375 | Complete Husky 716 (246482) supply pump system |
| 246376 | Complete Husky 1050 (246676) supply pump system |

Supply Pumps with Drum Riser Tube

| | |
|--------|---|
| 256200 | T1 2:1 ratio piston pump for higher viscosity materials, 360 psi max fluid psi, 2.5 gpm @ 100 cpm |
| 295616 | T2 2:1 ratio piston pump for higher viscosity materials, 405 psi max fluid psi, 5.0 gpm @ 100 cpm |
| 246654 | Triton 308 diaphragm pump, aluminum, 3/8 in fluid outlet, 115 psi max air inlet, 2.0 gpm @ 60 cpm, 1.7 cfm per gpm |
| 246366 | Husky 515 diaphragm pump, acetal bolted design, 100 psi max air inlet, 7.5 gpm @ 60 cpm, 3 cfm per gpm |
| 246367 | Husky 716 diaphragm pump, aluminum clamped design, 100 psi max air inlet, 7.5 gpm @ 60 cpm, 3 cfm per gpm |
| 246368 | Husky 1050 diaphragm pump for trailer mounts – aluminum, bolted, wall mount, 125 psi max air inlet, 9 gpm @ 60 cpm |
| 248825 | 5:1 Monark® drum pump, for high viscosity materials, 900 psi max fluid psi, 10 ft (3 m) hose, 3/4 npt (m), air regulator, manual 310863 |

Two Supply Pumps with Fluid Plumbing

| | |
|--------|---|
| 247956 | T1 pumps with supply hoses |
| 246898 | T2 pumps with supply hoses |
| 246677 | Triton 308 (246654), 10 ft x 3/4 in (3 m x 19 mm) supply hose |
| 246481 | Husky 515 (246366), 10 ft x 3/4 in (3 m x 19 mm) supply hose |
| 246482 | Husky 716 (246367), 10 ft x 3/4 in (3 m x 19 mm) supply hose |
| 246676 | Husky 1050 (246368), 10 ft x 3/4 in (3 m x 19 mm) supply hose, 6 ft x 3/4 in (1.8 m x 19 mm) suction hose |

Supply Pump Accessories

| | |
|--------|---|
| 246419 | 55 gal (208 l) feed pump tube with inlet ball check |
| 246477 | 3/4 in (19 mm) bung return tube with air dryer port |
| 246483 | Air distribution kit, 120 psi (8.4 bar, 0.84 MPa) for two feed pumps and a Fusion gun |
| 247616 | Desiccant dryer kit |
| 246978 | Reactor manifold circulation kit with return tubes, return fluid lines and dryers |
| 15C381 | Desiccant replacement |

Agitators

| | |
|--------|---|
| 224854 | Twistork CS, air-operated, 1-1/2 HP, 37.3 in (0.9 m) length |
| 235534 | Twistork SST, air-operated, 1-1/2 HP, 37.3 in (0.9 m) length |
| 236629 | Twistork SST, air-operated with built-in return tube, 3/4 HP, 47.5 in (1.2 m) in length |
| 248824 | Twistork CS, air-operated (224854), 1-1/2 HP, 37.3 in (0.9 m) with air hose |
| 24C728 | Expanding blade mixer, low viscosity, up to 1000 centipoise |
| 24C729 | Expanding blade mixer, high-viscosity, up to 2000 centipoise |



Liquid-Purge Guns

Fusion CS Gun, Round

| | |
|--------|--|
| CS20RD | RD2020 (000) round mix chamber (.020 orifice size) |
| CS00RD | RD0000 (00) round mix chamber (.029 orifice size) |
| CS01RD | RD0101 (01) round mix chamber (.042 orifice size) |
| CS02RD | RD0202 (02) round mix chamber (.052 orifice size) |
| CS03RD | RD0303 (03) round mix chamber (.060 orifice size) |

Fusion CS Gun, Wide Round

| | |
|--------|---|
| CS22WD | WD2222 wide mix chamber (.022 orifice size) |
| CS00WD | WD0000 wide mix chamber (.028 orifice size) |
| CS01WD | WD0101 wide mix chamber (.039 orifice size) |
| CS02WD | WD0202 wide mix chamber (.046 orifice size) |
| CS03WD | WD0303 wide mix chamber (.057 orifice size) |

Fusion CS Gun, Flat

| | |
|--------|---|
| CS20F1 | FL2020 mix chamber with FT0424 flat tip (.020 orifice size) |
| CS20F2 | FL2020 mix chamber with FT0438 flat tip (.020 orifice size) |
| CS00F1 | FL0000 mix chamber with FT0424 flat tip (.029 orifice size) |
| CS00F2 | FL0000 mix chamber with FT0438 flat tip (.029 orifice size) |
| CS00F3 | FL0000 mix chamber with FT0624 flat tip (.029 orifice size) |
| CS00F4 | FL0000 mix chamber with FT0638 flat tip (.029 orifice size) |
| CS00F5 | FL0000 mix chamber with FT0838 flat tip (.029 orifice size) |
| CS00F6 | FL0000 mix chamber with FT0848 flat tip (.029 orifice size) |
| CS01F1 | FL0101 mix chamber with FT0424 flat tip (.042 orifice size) |
| CS01F2 | FL0101 mix chamber with FT0438 flat tip (.042 orifice size) |
| CS01F3 | FL0101 mix chamber with FT0624 flat tip (.042 orifice size) |
| CS01F4 | FL0101 mix chamber with FT0638 flat tip (.042 orifice size) |
| CS01F5 | FL0101 mix chamber with FT0838 flat tip (.042 orifice size) |
| CS01F6 | FL0101 mix chamber with FT0848 flat tip (.042 orifice size) |
| CS02F1 | FL0202 mix chamber with FT0424 flat tip (.052 orifice size) |
| CS02F2 | FL0202 mix chamber with FT0438 flat tip (.052 orifice size) |
| CS02F3 | FL0202 mix chamber with FT0624 flat tip (.052 orifice size) |
| CS02F4 | FL0202 mix chamber with FT0638 flat tip (.052 orifice size) |
| CS02F5 | FL0202 mix chamber with FT0838 flat tip (.052 orifice size) |
| CS02F6 | FL0202 mix chamber with FT0848 flat tip (.052 orifice size) |

Fusion CS Parts and Accessories

| | |
|--------|---|
| 256385 | ClearShot Liquid Cartridges - pack of 25 |
| 256386 | ClearShot Liquid Cartridges - pack of 50 |
| 256387 | ClearShot Liquid Cartridges - pack of 100 |
| 117773 | Fusion grease (248280 - pack of 10) |
| 118665 | Fusion lube (248279 - pack of 10) |
| 246357 | Gun filter, 40 mesh - pack of 10 |
| 246358 | Gun filter, 60 mesh - pack of 10 |
| 246359 | Gun filter, 80 mesh - pack of 10 |
| 248132 | Fluid housing O-ring, large - pack of 6 |
| 248648 | Fluid housing O-ring, mix chamber - pack of 6 |
| 256414 | Cover retainer kit - pack of 5 |
| 256415 | Front cover, round kit - pack of 5 |
| 256416 | Front cover, tip kit - pack of 5 |
| 256454 | Air piston kit |
| 256455 | Spool valve kit |
| 256456 | Variable flow kit |
| 256457 | Front end replacement kit |
| 256459 | A Side valve kit |
| 256460 | B Side valve kit |
| 256461 | Fluid head checks kit |
| 256462 | Hose manifold checks kit |
| 256463 | Side seal housings kit |
| 256464 | Side seals kit |
| 256466 | Hose manifold kit |
| 256465 | Polycarbally seals kit, pack of 2 |
| 256469 | Hose manifold check O-rings kit |
| 256470 | Air piston O-ring kit |
| 256471 | Fluid head O-ring kit |
| 256472 | Back cap O-ring kit |
| 256467 | Side seal O-rings - pack of 6 |
| 256468 | Side seal housing O-rings - pack of 6 |
| 256489 | Polycarbally seals kit, pack of 20 |
| 256490 | Complete O-rings repair kit |
| 256510 | Fusion CS solvent flush kit |
| 256526 | Fusion CS gun clean out drill kit |
| 256566 | Fusion CS recirc manifold kit |
| 256567 | Tip retainer kit |
| 256569 | Fusion CS TP100 tip kit |
| 256570 | Fusion CS stud wall tip kit |
| 256640 | O-ring, fluid head checks kit - pack of 6 |
| 256641 | Fusion CS flush manifold kit |
| 258996 | CS Adapter Block, used with AP hose manifold |

| | |
|--------|--|
| 256642 | Inlet cover kit |
| 256650 | TP100 seals - pack of 5 |
| 256651 | Stud wall tip seals - pack of 5 |
| 256771 | Check valve O-ring, radial - pack of 6 |
| 256772 | Air piston O-ring, small - pack of 6 |
| 256773 | Fluid housing O-ring, small - pack of 6 |
| 256774 | Variable flow O-ring - pack of 6 |
| 256775 | Air piston O-ring, large - pack of 6 |
| 256923 | Side seal springs - pack of 10 |
| 256977 | Studwall retainer kit / TP 100 |
| 256978 | Studwall housing kit / TP 100 |
| 257142 | Polycarbally side seal housing kit |
| 257419 | Check valve spring - pack of 10 |
| 257420 | Check ball - pack of 10 |
| 257421 | Check valve retainer - pack of 10 |
| 257422 | Check valve kit, Fusion CS (ISO) |
| 257423 | Check valve kit, Fusion CS (resin) |
| 257424 | Dosing piston with O-rings |
| 257426 | Variable flow O-ring kit - pack of 6 |
| 257427 | Check valve housing (ISO) - pack of 10 |
| 257428 | Check valve housing (resin) - pack of 10 |

Fusion CS Mix Chamber Kits (Includes clean-out tools)

| | |
|--------|--------------------------------------|
| FL2020 | Fusion CS 2020 flat mix chamber kit |
| FL0000 | Fusion CS 2929 flat mix chamber kit |
| FL0101 | Fusion CS 4242 flat mix chamber kit |
| FL0202 | Fusion CS 5252 flat mix chamber kit |
| RD2020 | Fusion CS 2020 round mix chamber kit |
| RD0000 | Fusion CS 2929 round mix chamber kit |
| RD0101 | Fusion CS 4242 round mix chamber kit |
| RD0202 | Fusion CS 5252 round mix chamber kit |
| RD0303 | Fusion CS 6060 round mix chamber kit |
| WD2222 | Fusion CS 2222 wide mix chamber kit |
| WD0000 | Fusion CS 2828 wide mix chamber kit |
| WD0101 | Fusion CS 3939 wide mix chamber kit |
| WD0202 | Fusion CS 4646 wide mix chamber kit |
| WD0303 | Fusion CS 5757 wide mix chamber kit |



Air-Purge Guns

Fusion Air-Purge Guns, Round

| | |
|--------|---|
| 246099 | AR2020 (000) mix chamber (0.020 orifice size) |
| 246100 | AR2929 (00) mix chamber (0.029 orifice size) |
| 246101 | AR4242 (01) mix chamber (0.042 orifice size) |
| 246102 | AR5252 (02) mix chamber (0.052 orifice size) |
| 246103 | AR6060 (03) mix chamber (0.060 orifice size) |
| 246104 | AR7070 (04) mix chamber (0.070 orifice size) |
| 246105 | AR8686 (05) mix chamber (0.086 orifice size) |
| 248617 | AR3737 mix chamber, sized between AR2929 and AR4242 |
| 24D581 | AW2828 (00) wide round pattern |
| 249529 | AW3939 (01) wide round pattern |
| 249530 | AW4646 (02) wide round pattern |
| 248408 | Adhesive/spatter gun for fleeceback roofing systems |
| 249525 | Stud wall gun w/AF4242 and FTM979 |
| 249526 | Stud wall gun w/AF5252 and FTM979 |

Fusion Air-Purge Mix Chambers, Round (includes clean-out tools)

| | |
|--------|---|
| AR2020 | (000) mix chamber (0.020 orifice size) |
| AR2929 | (00) mix chamber (0.029 orifice size) |
| AR3737 | Mix chamber with (between 0.029 and 0.042 orifice size) |
| AR4242 | (01) mix chamber (0.042 orifice size) |
| AR5252 | (02) mix chamber (0.052 orifice size) |
| AR6060 | (03) mix chamber (0.060 orifice size) |
| AR7070 | (04) mix chamber (0.070 orifice size) |
| AR8686 | (05) mix chamber (0.086 orifice size) |

Ordering Information

To get genuine Graco accessories, see your nearest Graco distributor, or call Graco at 877-844-7226



Air-Purge Guns continued

Fusion Air-Purge Mix Chambers, Wide Round (Includes clean-out tools)

| | |
|--------|---------------------------------------|
| AW2222 | 50% wider pattern, compares to AR2020 |
| AW2828 | 50% wider pattern, compares to AR2929 |
| AW3333 | 50% wider pattern, compares to AR3737 |
| AW3939 | 50% wider pattern, compares to AR4242 |
| AW4646 | 50% wider pattern, compares to AR5252 |
| AW5757 | 50% wider pattern, compares to AR6060 |
| AW6464 | 50% wider pattern, compares to AR7070 |
| AW8282 | 50% wider pattern, compares to AR8686 |

Fusion Air-Purge Gun, Flat

| | |
|--------|---|
| 247101 | AF2020 mix chamber with FT0424 flat tip |
| 247102 | AF2020 mix chamber with FT0438 flat tip |
| 247103 | AF2020 mix chamber with FT0624 flat tip |
| 247104 | AF2020 mix chamber with FT0638 flat tip |
| 247107 | AF2020 mix chamber with FT0838 flat tip |
| 247108 | AF2020 mix chamber with FT0848 flat tip |
| 247111 | AF2929 mix chamber with FT0424 flat tip |
| 247112 | AF2929 mix chamber with FT0438 flat tip |
| 247113 | AF2929 mix chamber with FT0624 flat tip |
| 247114 | AF2929 mix chamber with FT0638 flat tip |
| 247117 | AF2929 mix chamber with FT0838 flat tip |
| 247118 | AF2929 mix chamber with FT0848 flat tip |
| 247121 | AF4242 mix chamber with FT0424 flat tip |
| 247122 | AF4242 mix chamber with FT0438 flat tip |
| 247123 | AF4242 mix chamber with FT0624 flat tip |
| 247124 | AF4242 mix chamber with FT0638 flat tip |
| 247127 | AF4242 mix chamber with FT0838 flat tip |
| 247128 | AF4242 mix chamber with FT0848 flat tip |
| 247131 | AF5252 mix chamber with FT0424 flat tip |
| 247132 | AF5252 mix chamber with FT0438 flat tip |
| 247133 | AF5252 mix chamber with FT0624 flat tip |
| 247134 | AF5252 mix chamber with FT0638 flat tip |
| 247137 | AF5252 mix chamber with FT0838 flat tip |
| 247138 | AF5252 mix chamber with FT0848 flat tip |

Fusion Air-Purge Mix Chambers, Flat (includes clean-out tool and O-ring)

| | | | |
|--------|-------------------|--------|-----------------------|
| AF2020 | (000) mix chamber | AF2033 | Off-ratio mix chamber |
| AF2929 | (00) mix chamber | AF2942 | Off-ratio mix chamber |
| AF4242 | (01) mix chamber | | |
| AF5252 | (02) mix chamber | | |

Fusion Air-Purge Tips, Flat

| | |
|--------|--|
| FT0424 | Low fluid flow, 8 to 10 in tip pattern |
| FT0438 | Medium fluid flow, 8 to 10 in pattern |
| FT0624 | Low fluid flow, 12 to 14 in tip pattern |
| FT0638 | Medium fluid flow, 12 to 14 in tip pattern |
| FT0838 | Medium fluid flow, 16 to 18 in pattern |
| FT0848 | High fluid flow, 16 to 18 in pattern |

Fusion Air-Purge with PolyCarballoy Options

| | |
|--------|---|
| 255201 | AP Fusion w/ PolyCarballoy side seal - AR4242(01) mix chamber |
| 255202 | AP Fusion w/ PolyCarballoy side seal - AR5252(02) mix chamber |
| 249990 | PolyCarballoy side seals, pack of 2 |
| 277298 | PolyCarballoy side seals, pack of 50 |

Fusion Air-Purge Parts and Accessories

| | |
|--------|---|
| 15B772 | 1/8 in (3.18 mm) air hose, 18 in (.46 m) long, use to attach gun to whip hose |
| 15D234 | Flat tip cleanout tool |
| 15B210 | Air cap, round pattern, for Fusion Air-Purge Gun |
| 15B801 | Air cap, flat pattern, for Fusion Air-Purge Gun |
| 15B565 | Ball valve |
| 15B817 | Gun flush manifold block |
| 15D546 | Fusion gun cleaning kit |
| 117509 | 1/4 npt male quick disconnect, air |
| 117510 | 1/4 npt female quick disconnect, air |
| 117661 | Pin vise, double-ended pin vise, with reversible chucks |

| | |
|--------|---|
| 117773 | Fusion grease (248280 – pack of 10) |
| 117792 | Fusion grease gun |
| 118665 | Fusion lube (248279 – pack of 10) |
| 119386 | Drill bit kit, 20 piece, #61 - #81 |
| 244914 | Air-Purge gun cover kit, pack of 10 |
| 246012 | Fluid manifold assembly |
| 246347 | Side seal O-ring kit, includes (6) O-rings for both cartridges |
| 246348 | Side seal kit, includes (2) side seals with O-rings |
| 246349 | A (ISO) cartridge assembly, A-side, SST, seal and O-rings |
| 246350 | B (Poly) cartridge assembly, B-side, SST, seal and O-rings |
| 246351 | Check valve seal repair kit |
| 246352 | Check valve assembly, B (Poly) |
| 246354 | O-ring, clean off air, pack of 6 |
| 246355 | Gun seal repair kit, includes all necessary O-rings for the entire gun assembly |
| 246356 | Fluid manifold valve repair kit |
| 246357 | Gun filter, 40 mesh, pack of 10 |
| 246358 | Gun filter, 60 mesh, pack of 10 |
| 246359 | Gun filter, 80 mesh, pack of 10 |
| 246360 | Flat tip sealing O-ring kit, pack of 3 |
| 246361 | Quick change front half spray head kit, includes entire spray head assembly less mix chamber. Order mix chamber separately. |
| 246731 | Check valve assembly, A (ISO) |
| 246944 | Manifold conversion kit; converts Fusion manifold to fit a GX-7 gun. Fusion manifold 246012 not included. |
| 246945 | Manifold conversion kit; converts GX-7 manifold to fit a Fusion gun |
| 248129 | Check valve O-ring, radial, pack of 6 |
| 248130 | Side seal housing O-ring kit, pack of 6 |
| 248132 | O-ring, fluid housing, pack of 6 |
| 248133 | Check valve O-ring, face, pack of 6 |
| 248139 | Solvent flush kit, 1 qt (.95 l) pressurized container for solvent flushing gun before service |
| 248229 | 5 gal Fusion Gun flush system |
| 248279 | Fusion lube for lubricating threads, O-rings, components, pack of 10 |
| 248280 | Fusion grease, pack of 10 |
| 248414 | Adhesive/spatter kit, converts Fusion Air-Purge to adhesive/spatter gun |
| 248415 | Tip for adhesive/spatter gun |
| 248528 | Fusion Air-Purge pour adapter kit |

Fusion Air-Purge Extension Tip Kits

| | |
|--------|---|
| 248010 | Extension tip kit for AR2020/AF2929 mix chamber |
| 248011 | Extension tip kit for AR2929/AF2929 mix chamber |
| 248012 | Extension tip kit for AR4242/AF4242 mix chamber |
| 248013 | Extension tip kit for AR5252/AF5252 mix chamber |
| 248014 | Extension tip kit for AR2020/AF2929 mix chamber |
| 248015 | Extension tip kit for AR2929/AF2929 mix chamber |
| 248016 | Extension tip kit for AR4242/AF4242 mix chamber |
| 248017 | Extension tip kit for AR5252/AF5252 mix chamber |
| 248020 | Extension tip air cap kit |
| 248018 | Flat extension tip seal kit |
| 248019 | Round extension tip seal kit |
| 249421 | Fusion stud wall kit |
| 24C358 | Fusion TP 100 tip kit |

P2 Guns

| | |
|--------|------------------------|
| GCP2R0 | Probler 2 Gun Assembly |
| GCP2R1 | Probler 2 Gun Assembly |
| GCP2R2 | Probler 2 Gun Assembly |
| GCP2R3 | Probler 2 Gun Assembly |
| GCP2R4 | Probler 2 Gun Assembly |
| GCP2R5 | Probler 2 Gun Assembly |
| GCP2RA | Probler 2 Gun Assembly |

P2 Elite Guns

| | |
|--------|-------------------------------|
| GCP3R0 | Probler P2 Elite Gun Assembly |
| GCP3R1 | Probler P2 Elite Gun Assembly |
| GCP3R2 | Probler P2 Elite Gun Assembly |
| GCP3R3 | Probler P2 Elite Gun Assembly |
| GCP3R4 | Probler P2 Elite Gun Assembly |
| GCP3R5 | Probler P2 Elite Gun Assembly |
| GCP3RA | Probler P2 Elite Gun Assembly |

P2 Auto Guns

| | |
|--------|-------------------------|
| GCP4R0 | Probler 2 Automatic Gun |
| GCP4R1 | Probler 2 Automatic Gun |
| GCP4R2 | Probler 2 Automatic Gun |
| GCP4R3 | Probler 2 Automatic Gun |
| GCP4R4 | Probler 2 Automatic Gun |
| GCP4R5 | Probler 2 Automatic Gun |
| GCP4RA | Probler 2 Automatic Gun |

P2 Spare Parts and Accessories

| | |
|--------|--|
| GC1703 | P2 recirculation kit |
| GC1892 | P2 Elite conversion kit |
| GC1937 | P2 standard repair kit |
| GC1938 | P2 flat spray kit |
| GC1946 | Side seal kit |
| GC1947 | P2 00-03 gun hardware kit |
| GC1948 | P2 AA gun hardware kit |
| GC1949 | P2 04-05 gun hardware kit |
| GC1950 | Premium repair kit |
| GC1952 | P2 0.059 jet nozzle |
| GC1953 | P2 0.07 jet nozzle |
| GC1954 | P2 pour cap |
| GC1955 | P2 LP/HP static mixer adapter |
| GC1956 | P2 static mixer assembly (non-nucleated) |
| GC1957 | P2 16-in stud wall spray tip |
| GC1958 | P2 24-in stud wall spray tip |
| GC1959 | P2 delay plug |
| GC1966 | P2 delayed air purge gun assembly |
| GC1967 | P2 dispense counter assembly |
| GC1968 | P2 stroke signal tee counter |
| GC2494 | P2 seal kit |
| GC2495 | P2 seal housing kit |
| GC2496 | P2 40 mesh filter kit |
| GC2497 | P2 100 mesh filter kit |
| GC2498 | P2 side seal kit |
| GC2499 | P2 handle kit |
| GC2500 | P2 round 00 mix chamber kit |
| GC2501 | P2 round 01 mix chamber kit |
| GC2502 | P2 round 02 mix chamber kit |
| GC2503 | P2 round 03 mix chamber kit |
| GC2504 | P2 round 04 mix chamber kit |
| GC2505 | P2 round 05 mix chamber kit |
| GC250A | P2 round AA mix chamber kit |
| GC2510 | Mix chamber 00 insert kit |
| GC2511 | Mix chamber 01 insert kit |
| GC2512 | Mix chamber 02 insert kit |
| GC2513 | Mix chamber 03 insert kit |
| GC2514 | Mix chamber 04 insert kit |
| GC2515 | Mix chamber 05 insert kit |
| GC251A | Mix chamber AA insert kit |
| 257988 | P2 Elite chopper attachment, B-410 |
| 257989 | P2 Elite chopper attachment, B-510 |

Gap Pro Gun

| | |
|--------|-----------------------------------|
| 295550 | GAP Pro flat package #00 chamber |
| 295551 | GAP Pro flat package #01 chamber |
| 295552 | GAP Pro flat package #02 chamber |
| 295553 | GAP Pro flat package #03 chamber |
| 295554 | GAP Pro flat package #04 chamber |
| 295557 | GAP Pro round package #00 chamber |
| 295558 | GAP Pro round #00 Recirc |
| 295559 | GAP Pro round package #01 chamber |
| 295560 | GAP Pro round package #02 chamber |
| 295561 | GAP Pro round package #03 chamber |
| 295562 | GAP Pro round package #04 chamber |

Gap Pro Gun Parts and Accessories

| | |
|--------|----------------------------------|
| 261293 | TP100 tip kit |
| 296348 | TP100 tip |
| 296840 | Mix chamber GAP Pro flat-00 |
| 296841 | Mix chamber GAP Pro flat-01 |
| 296842 | Mix chamber GAP Pro flat-02 |
| 296843 | Mix chamber GAP Pro flat-03 |
| 296844 | Mix chamber GAP Pro flat-04 |
| 296845 | Mix chamber GAP Pro flat-05 |
| 296846 | Mix chamber GAP Pro round-00 |
| 296847 | Mix chamber GAP Pro round-01 |
| 296848 | Mix chamber GAP Pro round-02 |
| 296849 | Mix chamber GAP Pro round-03 |
| 296850 | Mix chamber GAP Pro round-04 |
| 296851 | Mix chamber GAP Pro round-05 |
| 296942 | Screen screw seal kit, pack of 2 |
| 296945 | Air seal, small mix chamber |
| 296946 | Air seal, large mix chamber |
| 296953 | Check valve kit |
| 296956 | Side seal kit, pack of 2 |
| 296970 | Manual valve assembly |
| 296939 | 80 screen mesh kit, pack of 10 |



Mechanical-Purge Guns

Fusion Mechanical-Purge Guns, DI, Flat

| | |
|--------|---|
| 247050 | Fusion MP direct impingement, flat pattern XF1313, FTM317 |
| 247051 | Fusion MP direct impingement, flat pattern XF1313, FTM424 |
| 247057 | Fusion MP direct impingement, flat pattern XF1818, FTM317 |
| 247058 | Fusion MP direct impingement, flat pattern XF1818, FTM424 |
| 247061 | Fusion MP direct impingement, flat pattern XF2323, FTM424 |
| 247062 | Fusion MP direct impingement, flat pattern XF2323, FTM438 |
| 247063 | Fusion MP direct impingement, flat pattern XF2323, FTM624 |
| 247065 | Fusion MP direct impingement, flat pattern XF2929, FTM424 |
| 247066 | Fusion MP direct impingement, flat pattern XF2929, FTM438 |
| 247067 | Fusion MP direct impingement, flat pattern XF2929, FTM624 |
| 247073 | Fusion MP direct impingement, flat pattern XF3535, FTM438 |
| 247074 | Fusion MP direct impingement, flat pattern XF3535, FTM624 |
| 247075 | Fusion MP direct impingement, flat pattern XF3535, FTM638 |
| 247081 | Fusion MP direct impingement, flat pattern XF4747, FTM624 |
| 247082 | Fusion MP direct impingement, flat pattern XF4747, FTM638 |
| 247083 | Fusion MP direct impingement, flat pattern XF4747, FTM838 |
| 247089 | Fusion MP direct impingement, flat pattern XF5757, FTM638 |
| 247090 | Fusion MP direct impingement, flat pattern XF5757, FTM838 |
| 247091 | Fusion MP direct impingement, flat pattern XF5757, FTM848 |
| 247163 | Fusion MP direct impingement, flat pattern XF2332, FTM438 |

Fusion Mechanical-Purge Guns, Standard, Flat

| | |
|--------|---|
| 247257 | Fusion MP standard, flat pattern MF1818, FTM317 |
| 247258 | Fusion MP standard, flat pattern MF1818, FTM424 |
| 247265 | Fusion MP standard, flat pattern MF2929, FTM424 |
| 247266 | Fusion MP standard, flat pattern MF2929, FTM438 |
| 247267 | Fusion MP standard, flat pattern MF2929, FTM624 |
| 247273 | Fusion MP standard, flat pattern MF3535, FTM438 |
| 247274 | Fusion MP standard, flat pattern MF3535, FTM624 |
| 247275 | Fusion MP standard, flat pattern MF3535, FTM638 |
| 247281 | Fusion MP standard, flat pattern MF4747, FTM624 |
| 247282 | Fusion MP standard, flat pattern MF4747, FTM638 |
| 247283 | Fusion MP standard, flat pattern MF4747, FTM838 |
| 247289 | Fusion MP standard, flat pattern MF5757, FTM638 |
| 247290 | Fusion MP standard, flat pattern MF5757, FTM838 |
| 247291 | Fusion MP standard, flat pattern MF5757, FTM848 |

Ordering Information

To get genuine Graco accessories, see your nearest Graco distributor, or call Graco at 877-844-7226



Mechanical-Purge Guns continued

Fusion Mechanical-Purge Guns, DI, Round

| | |
|--------|--|
| 247003 | Fusion MP direct impingement, round pattern XR2323, RTM040 |
| 247006 | Fusion MP direct impingement, round pattern XR2929, RTM030 |
| 247007 | Fusion MP direct impingement, round pattern XR2929, RTM040 |
| 247011 | Fusion MP direct impingement, round pattern XR3535, RTM030 |
| 247012 | Fusion MP direct impingement, round pattern XR3535, RTM040 |
| 247013 | Fusion MP direct impingement, round pattern XR3535, RTM055 |
| 247018 | Fusion MP direct impingement, round pattern XR4747, RTM040 |
| 247019 | Fusion MP direct impingement, round pattern XR4747, RTM055 |
| 247025 | Fusion MP direct impingement, round pattern XR5757, RTM055 |
| 247026 | Fusion MP direct impingement, round pattern XR5757, RTM070 |

Fusion Mechanical-Purge Guns, Standard, Round

| | |
|--------|--|
| 247211 | Fusion MP standard, round pattern MR3535, RTM030 |
| 247212 | Fusion MP standard, round pattern MR3535, RTM040 |
| 247213 | Fusion MP standard, round pattern MR3535, RTM055 |
| 247218 | Fusion MP standard, round pattern MR4747, RTM040 |
| 247219 | Fusion MP standard, round pattern MR4747, RTM055 |
| 247225 | Fusion MP standard, round pattern MR5757, RTM055 |
| 247226 | Fusion MP standard, round pattern MR5757, RTM070 |
| 247231 | Fusion MP standard, round pattern MR6666, RTM070 |
| 247232 | Fusion MP standard, round pattern MR6666, RTM080 |
| 247233 | Fusion MP standard, round pattern MR6666, RTM090 |
| 247239 | Fusion MP standard, round pattern MR8282, RTM090 |
| 247240 | Fusion MP standard, round pattern MR8282, RTM100 |
| 247245 | Fusion MP standard, round pattern MR9494, RTM100 |
| 247246 | Fusion MP standard, round pattern MR9494, RTM110 |

Fusion Mechanical-Purge Mix Modules

| | |
|--------|--------------------------------------|
| MF1818 | Standard mix module, flat |
| MF2929 | Standard mix module, flat |
| MF3535 | Standard mix module, flat |
| MF4747 | Standard mix module, flat |
| MF5757 | Standard mix module, flat |
| MR3535 | Standard mix module, round |
| MR4747 | Standard mix module, round |
| MR5757 | Standard mix module, round |
| MR6666 | Standard mix module, round |
| MR8282 | Standard mix module, round |
| MR9494 | Standard mix module, round |
| XF1313 | Direct impingement mix module, flat |
| XF1318 | Direct impingement mix module, flat |
| XF1818 | Direct impingement mix module, flat |
| XF1824 | Direct impingement mix module, flat |
| XF2323 | Direct impingement mix module, flat |
| XF2332 | Direct impingement mix module, flat |
| XF2929 | Direct impingement mix module, flat |
| XF3535 | Direct impingement mix module, flat |
| XF4747 | Direct impingement mix module, flat |
| XF5757 | Direct impingement mix module, flat |
| XR2323 | Direct impingement mix module, flat |
| XR2929 | Direct impingement mix module, round |
| XR3535 | Direct impingement mix module, round |
| XR4747 | Direct impingement mix module, round |
| XR5757 | Direct impingement mix module, round |

Fusion Mechanical-Purge Round Tips

| | |
|--------|----------------------------------|
| RTM024 | Kit, round tip, mechanical-purge |
| RTM030 | Kit, round tip, mechanical-purge |
| RTM040 | Kit, round tip, mechanical-purge |
| RTM055 | Kit, round tip, mechanical-purge |
| RTM070 | Kit, round tip, mechanical-purge |
| RTM080 | Kit, round tip, mechanical-purge |
| RTM090 | Kit, round tip, mechanical-purge |
| RTM100 | Kit, round tip, mechanical-purge |
| RTM110 | Kit, round tip, mechanical-purge |

Fusion Mechanical-Purge Flat Tips

| | |
|--------|---|
| FTM317 | Kit, flat tip, mechanical-purge, 6 in (152 mm) pattern, very low flow |
| FTM424 | Kit, flat tip, mechanical-purge, 8 in (203 mm) pattern, low flow |
| FTM438 | Kit, flat tip, mechanical-purge, 8 in (203 mm) pattern, medium flow |
| FTM624 | Kit, flat tip, mechanical-purge, 12 in (305 mm) pattern, low flow |
| FTM638 | Kit, flat tip, mechanical-purge, 12 in (305 mm) pattern, medium flow |
| FTM838 | Kit, flat tip, mechanical-purge, 16 in (406 mm) pattern, medium flow |
| FTM848 | Kit, flat tip, mechanical-purge, 16 in (406 mm) pattern, high flow |

Fusion Mechanical-Purge Parts and Accessories

| | |
|--------|---|
| 244915 | Mechanical-Purge gun cover kit, pack of 10 |
| 248603 | Kit converts Fusion MP gun to Solvent-Purge |
| 248642 | Static mixer assembly for Solvent-Purge Gun, 3 in (76 mm) |
| 248682 | Fusion Mechanical pour adapter kit |
| 15D546 | Fusion gun cleaning kit |
| 119386 | Drill bit kit, 20-piece, #61-#81 |
| 248000 | Kit, complete O-ring, Fusion MP |
| 248001 | Kit, purge rod |
| 248003 | Kit, front/rear packing, pack of 4 |

Fusion Specialty Guns

| | |
|--------|---------------------------------------|
| 248408 | Fusion AP spatter/adhesive manual gun |
| 248597 | Manual Fusion solvent-purge gun |

Automatic Fusion (All Auto Fusion kits require 4-way solenoid valves)

| | |
|--------|--|
| 115807 | 4-way solenoid valve, 24 volt DC |
| 248376 | Automatic Fusion AP, round, AR2929 |
| 248377 | Automatic Fusion AP, round, AR4242 |
| 248378 | Automatic Fusion AP, round, AR5252 |
| 248379 | Automatic Fusion AP, round, AR6060 |
| 248380 | Automatic Fusion AP, flat, AF2020, FT0424 |
| 248381 | Automatic Fusion AP, flat, AF2929, FT0438 |
| 248382 | Automatic Fusion MP, round, direct impingement, XR2929, RTM040 |
| 248383 | Automatic Fusion MP, round, direct impingement, XR3535, RTM040 |
| 248384 | Automatic Fusion MP, flat, direct impingement, XF1313, FTM317 |
| 248385 | Automatic Fusion MP, flat, direct impingement, XF1818, FTM424 |
| 248386 | Automatic Fusion MP, round, MR3535, RTM040 |
| 248387 | Automatic Fusion MP, round, MR5757, RTM0702 |
| 248647 | Auto Fusion - Solvent-Purge |

GX-7 Guns

| | |
|--------|-------------------|
| 295542 | GX-7 1/90 Gun |
| 295543 | GX-7 10/210 Gun |
| 295544 | GX-7 3/70 Gun |
| 295545 | GX-7 5/70 Gun |
| 295541 | GX-7 DI 4/213 Gun |
| 295540 | GX-7-400 Gun |

GX-7, GX-7-DI Tips and Accessories

| | |
|--------|----------------------------------|
| 296128 | Coupling block gasket, pack of 2 |
| 296692 | Valving rod, 125 |
| 296693 | Screen screw seal kit, pack of 2 |
| 296694 | Round tip 100 |
| 296695 | Round tip 110 |
| 296697 | Round tip 125 |
| 256388 | Single piece valving rod |

| | |
|--------|-----------------------------------|
| 296698 | Fan tip 202 |
| 296700 | Fan tip 204 |
| 296701 | Fan tip 206 |
| 296702 | Fan tip 208 |
| 296703 | Fan tip 209 |
| 296704 | Fan tip 210 |
| 296705 | Fan tip 212 |
| 296706 | Fan tip 213 |
| 296707 | Fan tip 215 |
| 296708 | Round tip 40 |
| 296709 | Round tip 46 |
| 296710 | Round tip 70 |
| 296711 | Round tip 80 |
| 296712 | Round tip 90 |
| 296715 | Round tip 210 |
| 296716 | Round tip 212 |
| 296717 | Round tip 55, pack of 5 |
| 296718 | Round tip 70, pack of 5 |
| 296719 | Round tip 80, pack of 5 |
| 296720 | Round tip 90, pack of 5 |
| 296722 | Check valve kit, pack of 10 |
| 296723 | Screen screw seal kit, pack of 2 |
| 296792 | Screen screw seal kit, pack of 10 |
| 296724 | 80 mesh screen, package of 50 |
| 296829 | Rear packing seal, pack of 5 |
| 296882 | Fan tip 212.5 spec |
| 296883 | Fan tip 213.5 spec |

GX-7 Mix Module Kits

| | |
|--------|--|
| 296868 | Module, A5 pour |
| 296869 | Module, A5 pour, pack of 12 |
| 296870 | Module, A5-FS pour |
| 296871 | Module, A5-FS pour, pack of 12 |
| 296872 | Module, A10 pour, pack of 12 |
| 296873 | Module, A20 pour, pack of 12 |
| 296874 | Module, A2 pour, pack of 12 (with 2 drills) |
| 296875 | Module, A2 pour |
| 296876 | Module, A3 pour |
| 296885 | Fan module, #402 round |
| 296888 | Fan module, #452 fan |
| 296891 | Fan module, #453 fan |
| 296901 | Ported module, #4 |
| 296903 | Ported module, #5 |
| 296906 | Round module, #10 |
| 296908 | Round module, #1, pack of 12 (with 2 drills) |
| 296909 | Round module, #1 |
| 296910 | Flat module, #12 |
| 296915 | Round module, #16 |
| 296916 | Round module, #2 |
| 296917 | Round module, #22 |
| 296919 | Round module, ported #3 |
| 296921 | Round module, ported #4 |
| 296923 | Round module, ported #5 |
| 296924 | Round module, ported #53 |
| 296925 | Fan module, ported #7 flat |
| 296970 | Manual valve |
| 296978 | Front packing |
| 295868 | PCD retainer O-ring |

GX-7 DI Mix Module Kits

| | |
|--------|---------------|
| 296900 | Fan module #2 |
| 296901 | Fan module #4 |
| 296903 | Fan module #5 |

GX-7 400 Mix Module Kits

| | |
|--------|------------------------------|
| 296885 | Round module 402 |
| 296884 | Round module 402, pack of 12 |
| 296859 | Fan module 451 |
| 296860 | Fan module 451, pack of 12 |
| 296888 | Fan module 452 |
| 296887 | Fan module 452, pack of 12 |
| 296891 | Fan module 453 |
| 296890 | Fan module 453, pack of 12 |

GX-7 400 Tip Kits

| | |
|--------|--------------------|
| 296858 | Round 40 |
| 296852 | Fan 210 |
| 296853 | Fan 212 |
| 296854 | Fan 212, pack of 5 |
| 296855 | Fan 213 |
| 296856 | Fan 213, pack of 5 |
| 296857 | Fan 214 |
| 296892 | Fan TOM |

D-Gun

| | |
|--------|-----------------------------|
| 295530 | D-Gun 55 mix chamber |
| 295531 | D-Gun 55 mix chamber recirc |
| 295532 | D-Gun 62 mix chamber |
| 295533 | D-Gun 70 mix chamber |

D-Gun Parts and Accessories

| | |
|--------|-----------------------------------|
| 296584 | Mix chamber 46, L800 |
| 296585 | Mix chamber 46, L-810 |
| 296586 | Mix chamber 55, L |
| 296587 | Mix chamber 55, L |
| 296588 | Mix chamber 70, L |
| 296594 | Mix Chamber 46, N-800 |
| 296595 | Mix chamber 46, N-810 |
| 296597 | Mix chamber 55, N |
| 296598 | Mix chamber 62, N |
| 296599 | Mix chamber 70, N |
| 296600 | Mix chamber 78, N |
| 296578 | Valving Rod D-Gun 46 |
| 296579 | Valving Rod D-Gun 55 |
| 296580 | Valving Rod D-Gun 62 |
| 296581 | Valving Rod D-Gun 70 |
| 296582 | Valving Rod D-Gun 78 |
| 296634 | Air Cap, D-Gun 55/62 |
| 296635 | Air Cap, D-Gun 70/78 |
| 296838 | Air Cap, D-Gun 46 |
| 296621 | Screen screw seal kit, pack of 10 |
| 296622 | 80 mesh screen kit, pack of 10 |
| 296623 | 80 mesh screen kit, pack of 50 |
| 296611 | Felt wiper kit, pack of 5 |
| 296125 | Air valve repair kit |
| 296725 | Air cylinder seal kit |
| 296614 | Check Valve-A, D-Gun, pack of 10 |
| 296615 | Check Valve-R, D-Gun, pack of 10 |

GX-8 Gun and Accessories

| | |
|--------|---------------------------------------|
| 297898 | GX-8 Gun, with 013 module |
| 297832 | GX-8 Gun with starter and service kit |
| 295377 | 013 round module, pack of 5 |
| 295339 | 020 round tip |
| 295428 | 024 round tip |
| 295338 | 013 fan module |
| 297192 | 201 fan tip |
| 297841 | 202 fan tip |



ABOUT GRACO

PROVEN QUALITY. LEADING TECHNOLOGY.

Founded in 1926, Graco is a world leader in fluid handling systems and components. Graco products move, measure, control, dispense and apply a wide range of fluids and viscous materials used in vehicle lubrication, commercial and industrial settings.

The company's success is based on its unwavering commitment to technical excellence, world-class manufacturing and unparalleled customer service. Working closely with qualified distributors, Graco offers systems, products and technology that set the quality standard in a wide range of fluid handling solutions. Graco provides equipment for spray finishing, protective coating, paint circulation, lubrication, and dispensing sealants and adhesives, along with power application equipment for the contractor industry. Graco's ongoing investment in fluid management and control will continue to provide innovative solutions to a diverse global market.

GRACO LOCATIONS

MAILING ADDRESS

P.O. Box 1441
Minneapolis, MN 55440-1441
Tel: 612-623-6000
Fax: 612-623-6777

AMERICAS

MINNESOTA

Worldwide Headquarters
Graco Inc.
88-11th Avenue N.E.
Minneapolis, MN 55413

EUROPE

BELGIUM

European Headquarters
Graco N.V.
Industrieterrein-Oude Bunders
Slakweidestraat 31
3630 Maasmechelen,
Belgium
Tel: 32 89 770 700
Fax: 32 89 770 777

ASIA PACIFIC

AUSTRALIA

Graco Australia Pty Ltd.
Suite 17, 2 Enterprise Drive
Bundoora, Victoria 3083
Australia
Tel: 61 3 9468 8500
Fax: 61 3 9468 8599

CHINA

Graco Hong Kong Ltd.
Shanghai Representative Office
Room 118 1st Floor
No.2 Xin Yuan Building
No.509 Cao Bao Road
Shanghai, 200233
The People's Republic of China
Tel: 86 21 649 50088
Fax: 86 21 649 50077

INDIA

Graco Hong Kong Ltd.
India Liaison Office
Room 432, Augusta Point
Regus Business Centre 53
Golf Course Road
Gurgaon, Haryana
India 122001
Tel: 91 124 435 4208
Fax: 91 124 435 4001

JAPAN

Graco K.K.
1-27-12 Hayabuchi
Tsuzuki-ku
Yokohama City, Japan 2240025
Tel: 81 45 593 7300
Fax: 81 45 593 7301

KOREA

Graco Korea Inc.
Shinhan Bank Building
4th Floor #1599
Gwanyang-Dong, Dongan-Ku,
Anyang-si, Korea 431-060
Tel: 82 31 476 9400
Fax: 82 31 476 9801

SALES/ DISTRIBUTION/ SERVICE

Call today for product information or to request a demonstration.

877-84GRACO (1-877-844-7226) or visit us at www.graco.com.

Graco Inc. is registered to I.S. EN ISO 9001

North America
Customer Service
800-328-0211
Fax 877-340-6427