

T1 2:1 Ratio Transfer Pump

312766P
EN

For use with polyurethane foam, polyurea, and solvent-borne and water-borne materials.
For professional use only.

Model 256200

55 Gallon (200 Liter) Drum Size

180 psi (1.2 MPa, 12 bar) Maximum Air Working Pressure

360 psi (2.5 MPa, 25 bar) Maximum Fluid Working Pressure



Important Safety Instructions

Read all warnings and instructions in this manual. Save these instructions.

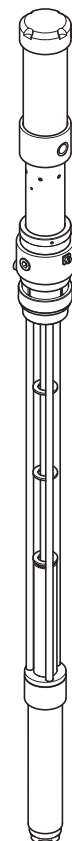

T117170a







II 1/2 G T6
ITS03ATEX11227

Contents

Warnings	3
Isocyanate Hazard	5
Moisture Sensitivity of Isocyanates	5
Foam Self-Ignition	6
Keep Components A and B Separate	6
Changing Materials	6
Typical Installation	7
Typical Installation without Circulation	7
Typical Installation with Circulation	8
Typical Installation for Lubrication Applications ..	9
Installation	10
System Accessories	10
Air Line Accessories	10
Fluid Line Accessories	10
Setup	11
Grounding	12
Operation	13
Pressure Relief Procedure	13
Flush Pump Before Use	13
Flushing	13
Daily Startup	14
Daily Shutdown	14
Repair	15
Before you start	15
Air Motor Disassembly	15
Air Motor Reassembly	16
Pump Lower Disassembly	17
Pump Lower Reassembly	19
Troubleshooting	21
Parts	22
Accessories	24
Dimensions	26
Technical Data	27
Performance Chart	28
Graco Standard Warranty	30
Graco Information	30

Warnings

The following warnings are for the setup, use, grounding, maintenance, and repair of this equipment. The exclamation point symbol alerts you to a general warning and the hazard symbol refers to procedure-specific risk. Refer back to these warnings. Additional, product-specific warnings may be found throughout the body of this manual where applicable.

 WARNING	
	<p>TOXIC FLUID OR FUMES HAZARD</p> <p>Toxic fluids or fumes can cause serious injury or death if splashed in the eyes or on skin, inhaled, or swallowed.</p> <ul style="list-style-type: none"> • Read MSDS's to know the specific hazards of the fluids you are using. • Store hazardous fluid in approved containers, and dispose of it according to applicable guidelines. • Always wear impervious gloves when spraying or cleaning equipment.
	<p>PERSONAL PROTECTIVE EQUIPMENT</p> <p>You must wear appropriate protective equipment when operating, servicing, or when in the operating area of the equipment to help protect you from serious injury, including eye injury, inhalation of toxic fumes, burns, and hearing loss. This equipment includes but is not limited to:</p> <ul style="list-style-type: none"> • Protective eyewear • Clothing and respirator as recommended by the fluid and solvent manufacturer • Gloves • Hearing protection
	<p>FIRE AND EXPLOSION HAZARD</p> <p>Flammable fumes, such as solvent and paint fumes, in work area can ignite or explode. To help prevent fire and explosion:</p> <ul style="list-style-type: none"> • Use equipment only in well ventilated area. • Eliminate all ignition sources; such as pilot lights, cigarettes, portable electric lamps, and plastic drop cloths (potential static arc). • Keep work area free of debris, including solvent, rags and gasoline. • Do not plug or unplug power cords, or turn power or light switches on or off when flammable fumes are present. • Ground all equipment in the work area. See Grounding instructions. • Use only grounded hoses. • Hold gun firmly to side of grounded pail when triggering into pail. • If there is static sparking or you feel a shock, stop operation immediately. Do not use equipment until you identify and correct the problem. • Keep a working fire extinguisher in the work area.

 **WARNING**



EQUIPMENT MISUSE HAZARD

Misuse can cause death or serious injury.

- Do not operate the unit when fatigued or under the influence of drugs or alcohol.
- Do not exceed the maximum working pressure or temperature rating of the lowest rated system component. See **Technical Data** in all equipment manuals.
- Use fluids and solvents that are compatible with equipment wetted parts. See **Technical Data** in all equipment manuals. Read fluid and solvent manufacturer's warnings. For complete information about your material, request MSDS forms from distributor or retailer.
- Check equipment daily. Repair or replace worn or damaged parts immediately with genuine manufacturer's replacement parts only.
- Do not alter or modify equipment.
- Use equipment only for its intended purpose. Call your distributor for information.
- Route hoses and cables away from traffic areas, sharp edges, moving parts, and hot surfaces.
- Do not kink or over bend hoses or use hoses to pull equipment.
- Keep children and animals away from work area.
- Comply with all applicable safety regulations.



PRESSURIZED EQUIPMENT HAZARD

Fluid from the gun/dispense valve, leaks, or ruptured components can splash in the eyes or on skin and cause serious injury.

- Follow **Pressure Relief Procedure** in this manual, when you stop spraying and before cleaning, checking, or servicing equipment.
- Tighten all fluid connections before operating the equipment.
- Check hoses, tubes, and couplings daily. Replace worn or damaged parts immediately.



MOVING PARTS HAZARD

Moving parts can pinch or amputate fingers and other body parts.

- Keep clear of moving parts.
- Do not operate equipment with protective guards or covers removed.
- Pressurized equipment can start without warning. Before checking, moving, or servicing equipment, follow the **Pressure Relief Procedure** in this manual. Disconnect power or air supply.

Isocyanate Hazard



Spraying materials containing isocyanates creates potentially harmful mists, vapors, and atomized particulates.

Read material manufacturer's warnings and material MSDS to know specific hazards and precautions related to isocyanates.

Prevent inhalation of isocyanate mists, vapors, and atomized particulates by providing sufficient ventilation in the work area. If sufficient ventilation is not available, a supplied-air respirator is required for everyone in the work area.

To prevent contact with isocyanates, appropriate personal protective equipment, including chemically impermeable gloves, boots, aprons, and goggles, is also required for everyone in the work area.

To prevent exposing ISO to moisture:

- Always use a sealed container with a desiccant dryer in the vent, or a nitrogen atmosphere. **Never** store ISO in an open container.
- Use moisture-proof hoses specifically designed for ISO, such as those supplied with your system.
- Never use reclaimed solvents, which may contain moisture. Always keep solvent containers closed when not in use.
- Never use solvent on one side if it has been contaminated from the other side.
- Always lubricate threaded parts with Part 217374 ISO pump oil or grease when reassembling.



Moisture Sensitivity of Isocyanates

Isocyanates (ISO) are catalysts used in two component foam and polyurea coatings. ISO will react with moisture (such as humidity) to form small, hard, abrasive crystals, which become suspended in the fluid. Eventually a film will form on the surface and the ISO will begin to gel, increasing in viscosity. If used, this partially cured ISO will reduce performance and the life of all wetted parts.



The amount of film formation and rate of crystallization varies depending on the blend of ISO, the humidity, and the temperature.

Foam Self-Ignition

				
<p>Some materials may become self-igniting if applied too thick. Read material manufacturer's warnings and material MSDS.</p>				

Keep Components A and B Separate

<p style="text-align: center;">CAUTION</p>
<p>To prevent cross-contamination of the equipment's wetted parts, never interchange component A and component B.</p>

Changing Materials

- When changing materials, flush the equipment multiple times to ensure it is thoroughly clean.
- Check with your material manufacturer for chemical compatibility.
- Some materials use catalyst on the A side, but some applications may use catalyst on the B side.
- Epoxies often have amines on the B (catalyst) side. Polyurethanes often have amines on the B (resin) side.

Typical Installation

Typical Installation without Circulation

Key for FIG. 1.

- A Reactor[®] Proportioner
- B Heated Hose
- C Fluid Temperature Sensor (FTS)
- D Heated Whip Hose
- E Fusion[®] Spray Gun
- F Proportioner and Gun Air Supply Hose

- G Feed Pump Air Supply Lines 3/8 in. (76 mm) ID min.
- H Waste Containers
- J Fluid Supply Lines (217382)
- K Feed Pumps
- L Agitator
- M Desiccant Dryer
- N Bleed Lines/Over Pressure Relief
- P Gun Fluid Manifold

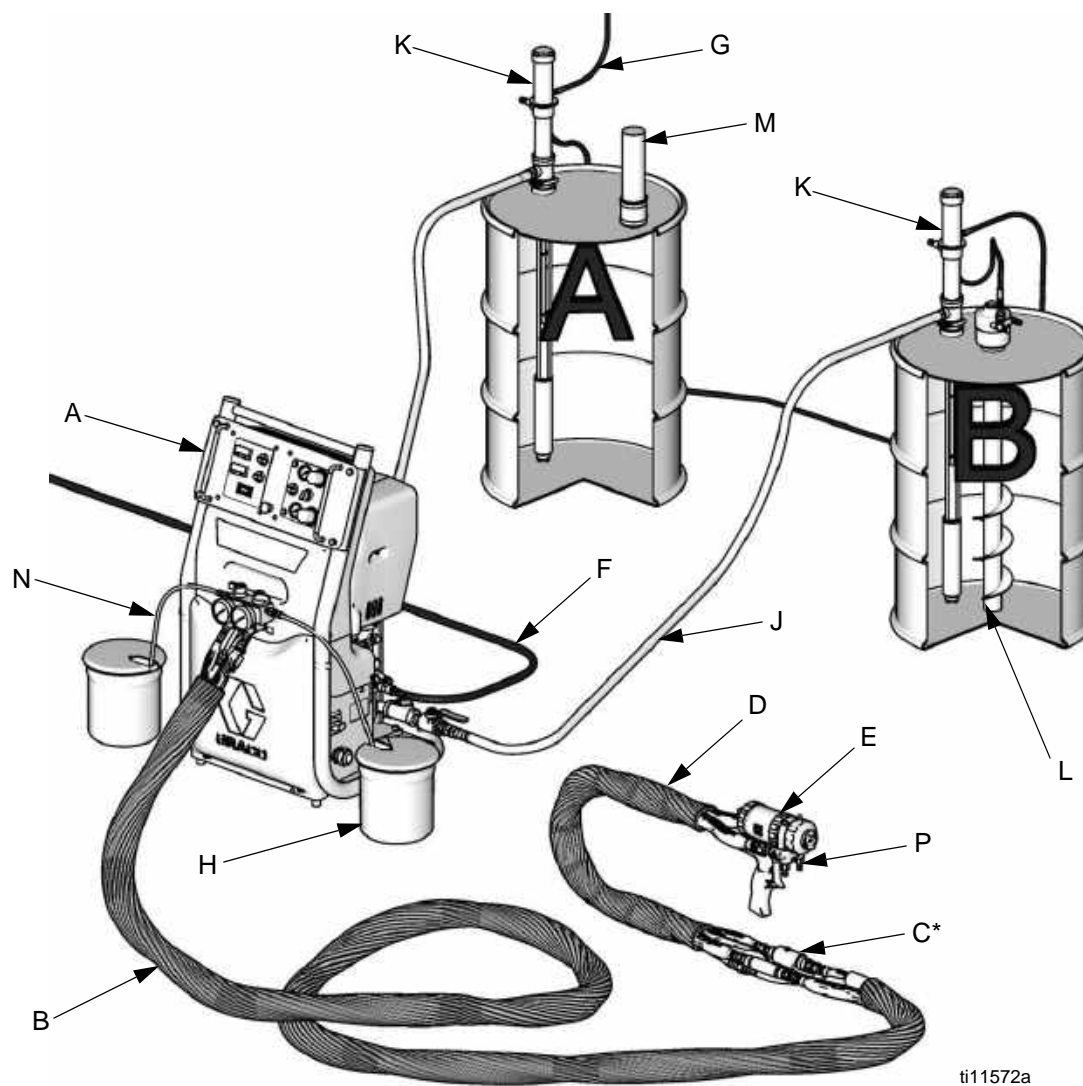

ti11572a

* Shown exposed for clarity. Wrap with tape during operation.

FIG. 1: Typical Installation without Circulation

Typical Installation with Circulation

Key for FIG. 2.

- A Reactor Proportioner
- B Heated Hose
- C Fluid Temperature Sensor (FTS)
- D Heated Whip Hose
- E Fusion Spray Gun
- F Proportioner and Gun Air Supply Hose

- G Feed Pump Air Supply Lines 3/8 in. (76 mm) ID min.
- J Fluid Supply Lines (217382)
- K Feed Pumps
- L Agitator
- M Desiccant Dryer
- N Bleed Lines/Over Pressure Relief
- P Gun Fluid Manifold

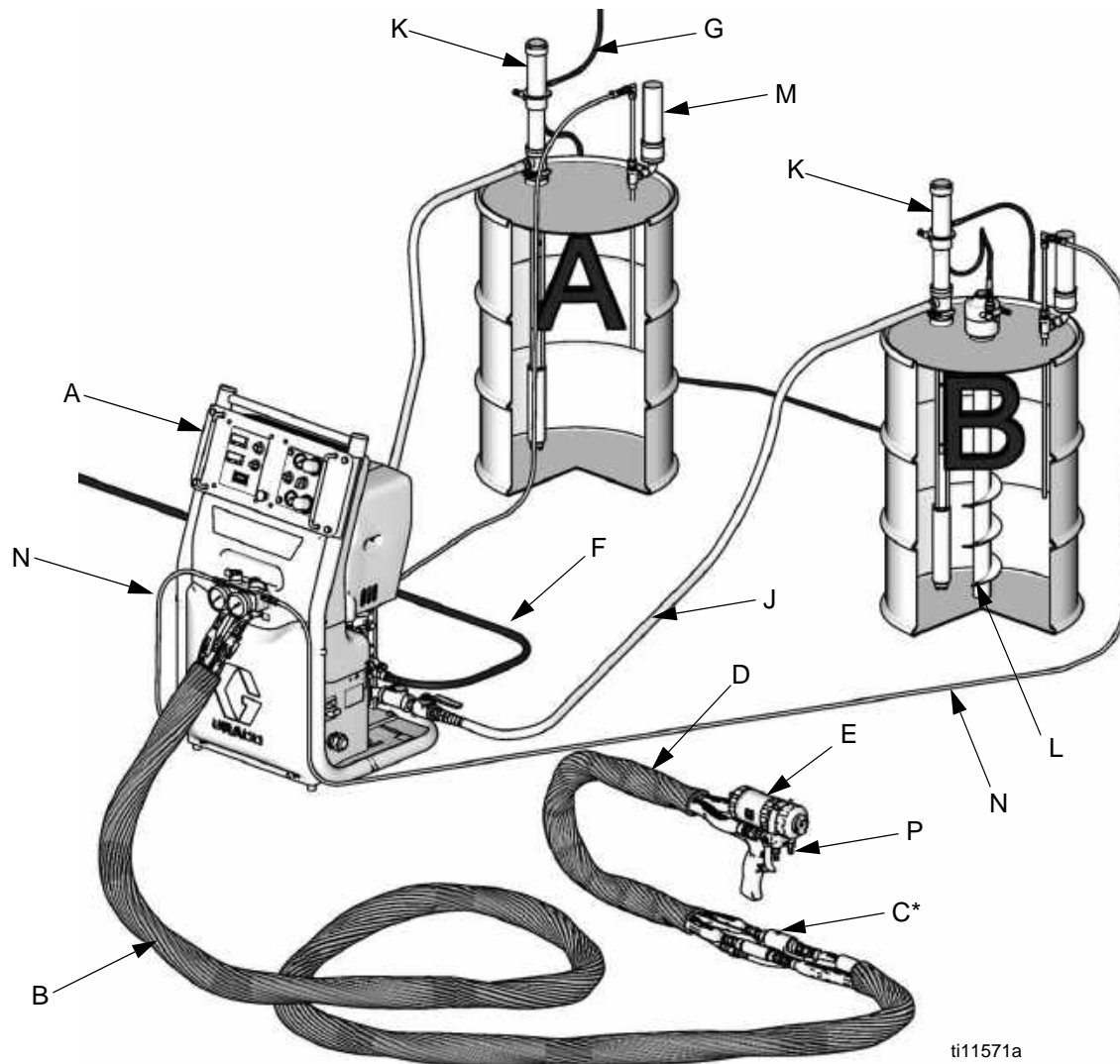

* Shown exposed for clarity. Wrap with tape during operation.

FIG. 2: Typical Installation with Circulation

Typical Installation for Lubrication Applications

Key for FIG. 3.

AA	Pump Air Regulator	AF	Bung Adapter
AB	Air Line Lubricator	AG	Grounded Air Hose
AC	Air Line Filter	AH	Grounded Fluid Hose
AD	Bleed-Type Master Air Valve (required, for pump)	AJ	Pump Fluid Inlet
AE	Fluid Drain Valve (required)	AK	1/4 npt(f) Pump Air Inlet
		AL	1/2 npt(f) Pump Fluid Outlet
		AM	Return Port

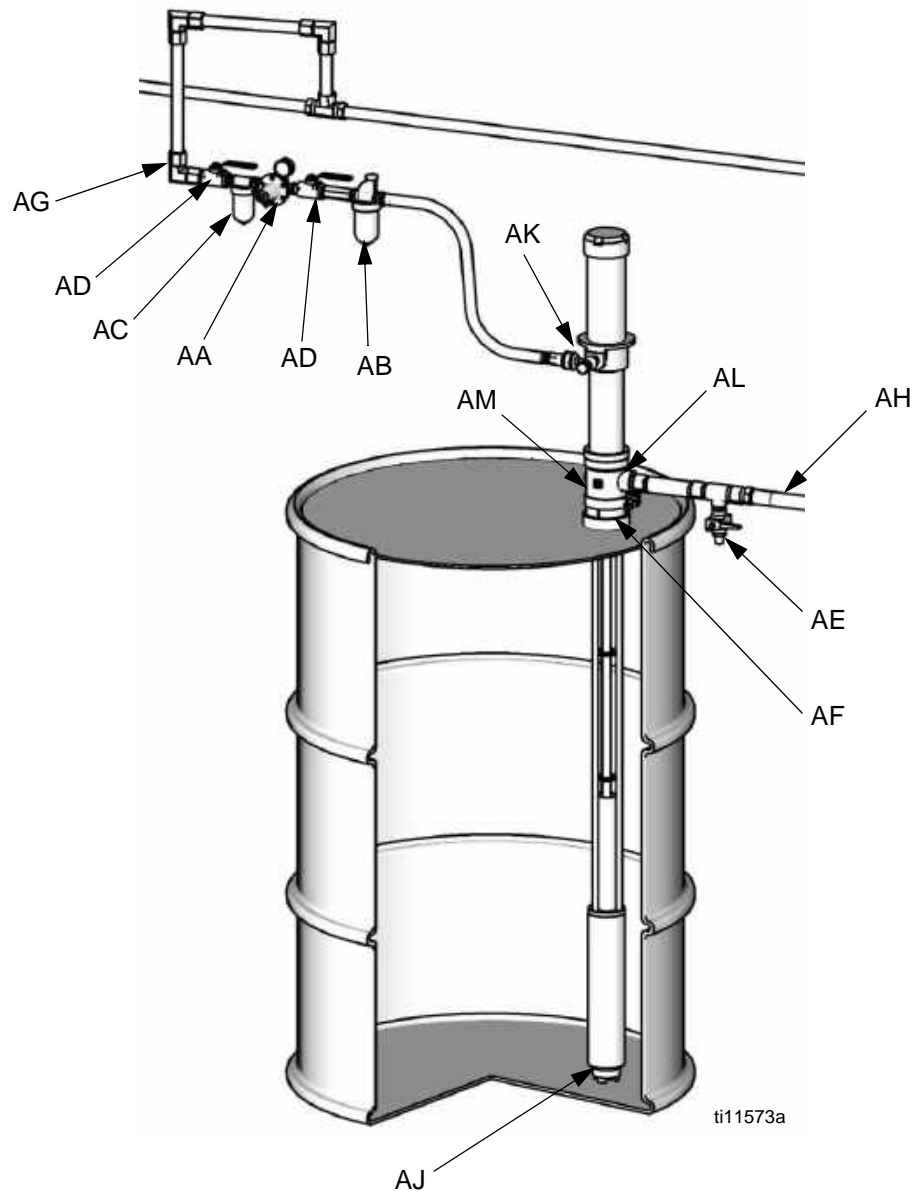
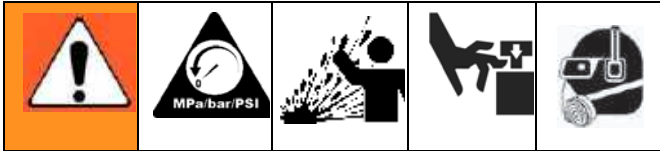

FIG. 3: Typical Installation for Lubrication Applications

Installation



A bleed-type master air valve (AD) and a fluid drain valve (AE) are required in your system, to help reduce the risk of serious injury, including splashing fluid in the eyes or on the skin, and injury from moving parts when you are adjusting or repairing the pump.

The bleed-type master air valve (AD) relieves air trapped between this valve and the pump after the pump is shut off. Trapped air can cause the pump to cycle unexpectedly and result in serious injury, including amputation. Install the valve close to the pump.

The fluid drain valve (AE) helps relieve pressure in the displacement pump, hose, and dispensing valve when shutting off the pump. Actuating the dispensing valve to relieve pressure may not be sufficient, especially if there is a clog in the hose or the dispensing valve.

A bleed-type master air valve (AD) is required in your system to relieve air trapped between it and the air motor when the valve is closed (see the WARNING on left). Be sure the bleed valve is easily accessible from the pump, and is located downstream from the air regulator.

An air line filter (AC) to remove harmful dirt and moisture from the compressed air supply.

A second bleed-type air valve (AD) isolates the air line accessories for servicing. Locate upstream from all other air line accessories.

Fluid Line Accessories

A fluid drain valve (AE) is required in your system to relieve fluid pressure in the hose and gun (see the WARNING on left). Install the drain valve so that it points down and the handle points up when the valve is opened.

System Accessories

Refer to FIG. 3 and the **Accessories** on page 24.



To ensure maximum pump performance, be sure that all accessories used are properly sized to meet your system's requirements.

Air Line Accessories

Install the following accessories in the order shown in the **Typical Installation for Lubrication Applications**, using adapters as necessary:

An air line lubricator (AB) provides automatic air motor lubrication.

Setup

1. Apply thread sealant to the male threads of the air needle valve (54) and the quick disconnect fitting (55). Install into inlet port (AK).

△ Apply thread sealant

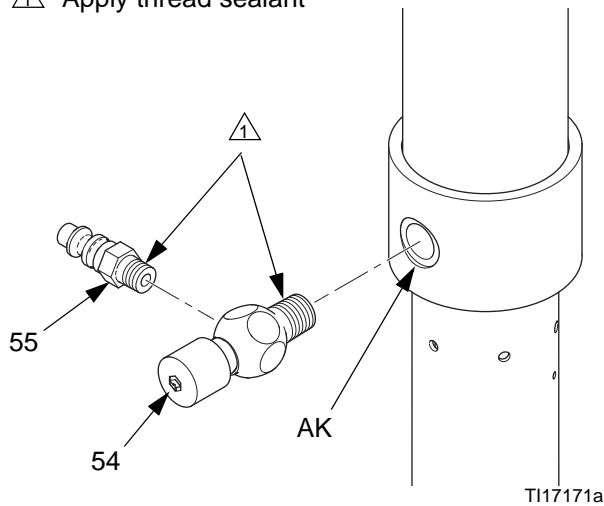

FIG. 4

2. Apply thread sealant to the male outlet fitting (BC) (not supplied) and insert into the outlet port (AL).

△ Apply thread sealant

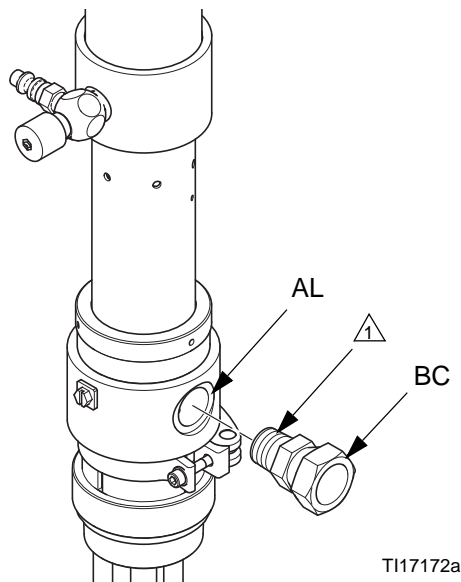

FIG. 5

3. Use labels (25) provided to identify the appropriate pump for your material.

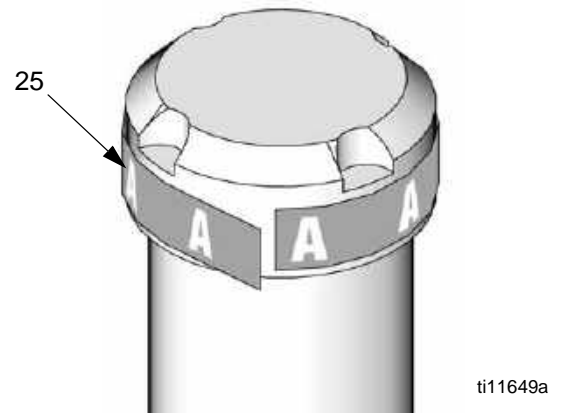

FIG. 6

4. Lubricate the bung adapter (16) inside diameter and mounting threads. Ensure the gasket is in place and screw the bung adapter (16) securely into the bunghole of the drum. Insert the pump through the adapter (16) and lock it in place.

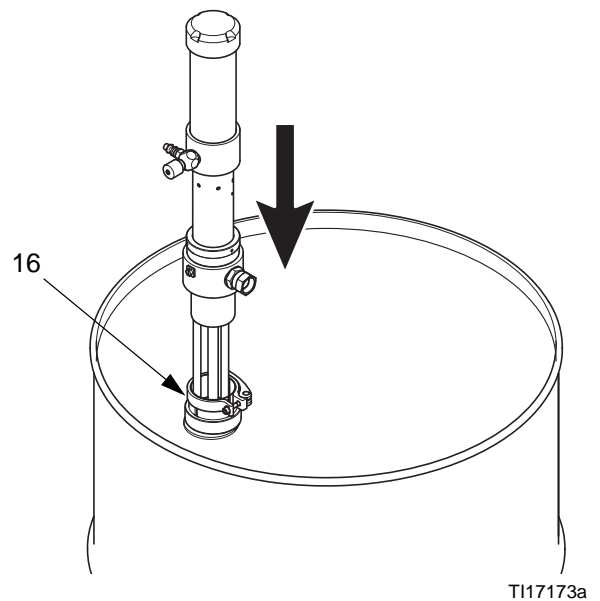

FIG. 7

Setup

5. Install air line (3/8 in. (76 mm) ID minimum) with quick disconnect air coupler (56).

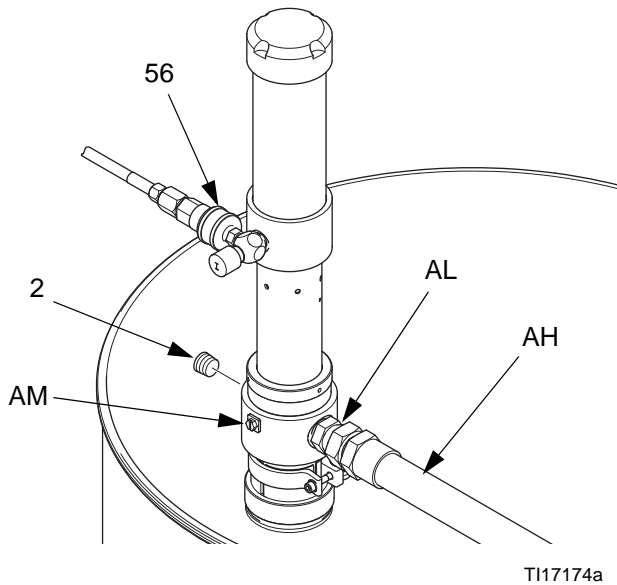
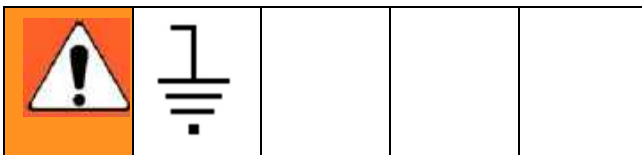

FIG. 8

6. Connect a grounded fluid hose (AH) to the 1/2 npt(f) fluid outlet (AL). In a circulating system, remove the pipe plug (2) and connect a fluid return line to the 3/8 npt(f) return port (AM).

Grounding



To reduce the risk of static sparking, ground the pump and all other equipment used or located in the pumping area. Check your local electrical code for detailed grounding instructions for your area and type of equipment. **Ground all of this equipment.**

1. *Pump*: Connect Ground Wire (Y) to grounding screw (24) and tighten the screw securely. See FIG. 9. Connect the other end

of the wire to a true earth ground. Make certain to comply with all National, State, and Local Electrical Codes.

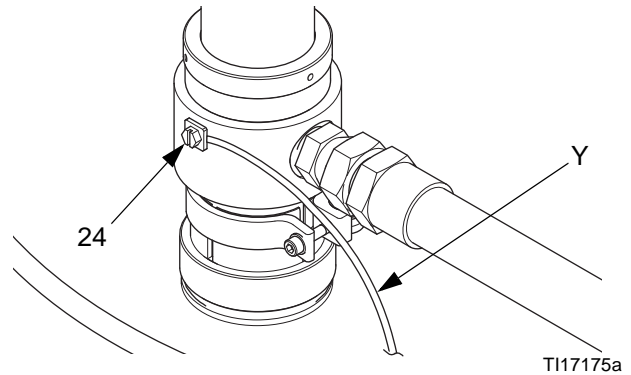
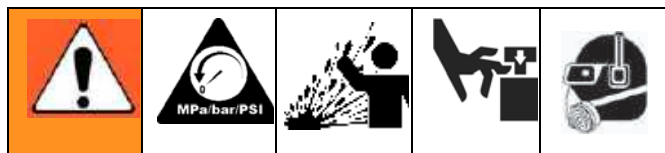

FIG. 9

2. *Air compressor*: according to manufacturer's recommendations.
3. *Fluid hoses*: use only grounded hoses with a maximum of 300 ft (91 m) combined hose length to ensure grounding continuity.
4. *Dispensing valve*: grounding is obtained through connection to a properly grounded fluid hose and pump.
5. *Object being sprayed*: according to local code.
6. *Fluid supply container*: according to local code.
7. *All solvent pails used when flushing*, according to local code. Use only metal pails, which are conductive. Do not place the pail on a non-conductive surface, such as paper or cardboard, which interrupts the grounding continuity.
8. *To maintain grounding continuity when flushing or relieving pressure*, always hold a metal part of the spray gun/dispensing valve firmly to the side of a grounded *metal* pail, then trigger the gun/valve.

Operation

Pressure Relief Procedure



Trapped air can cause the pump to cycle unexpectedly, which could result in serious injury from splashing or moving parts.

1. Shut off the air to the pump.
2. Close the bleed-type master air valve (AD).
3. Hold a metal part of the dispense valve firmly to a grounded metal pail. Trigger the valve to relieve pressure.
4. Open all fluid drain valves in the system, having a waste container ready to catch drainage. Leave drain valve(s) open until you are ready to dispense again.
5. If you suspect the nozzle or hose is clogged or that pressure has not been fully relieved after following the steps above, **VERY SLOWLY** loosen the hose end coupling to relieve pressure gradually, then loosen completely. Clear hose or nozzle obstruction.

Flush Pump Before Use

The pump is tested with lightweight oil, which is left in to protect the pump parts. To prevent contamination of the fluid you are pumping, flush the pump with a compatible solvent before using it. See **Flushing**, page 13.

Flushing



- Flush at the lowest pressure possible. Check connectors for leaks and tighten as necessary.
- Flush with a fluid that is compatible with the fluid being dispensed and the equipment wetted parts.

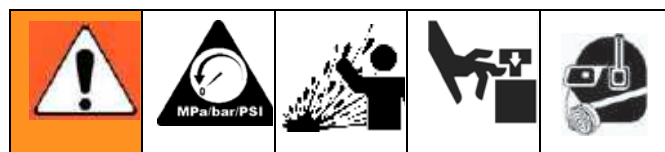

Trapped air can cause the pump to cycle unexpectedly, which could result in serious injury from splashing or moving parts.

1. Follow **Pressure Relief Procedure**, page 13.
2. Place suction tube in grounded metal drum containing cleaning fluid.
3. Set pump to lowest possible fluid pressure, and start pump.
4. Hold a metal part of the dispense valve firmly to a grounded metal pail. Trigger the dispense valve until clean solvent dispenses.
5. Remove valve from hose.
6. Follow **Pressure Relief Procedure**, and remove fluid filter and soak in solvent. Replace filter cap.
7. Cycle the pump slowly for at least 5 minutes, then stop and disconnect the air hose.
8. Push up on the ball (5) of the intake valve (29) to drain the lower part of the pump.
9. Turn the pump over to drain the upper part of the pump.

Daily Startup

1. Verify that the air needle valve (54) is closed.
2. Connect the air line quick disconnect coupler (55) to the transfer pump.
3. Turn on the main air supply.
4. Slowly open the air needle valve until the transfer pump runs slowly.
5. Use the air needle valve to control the pump speed.

Caution

Never allow the pump to run dry. A dry pump will quickly accelerate to a high speed and can damage the pump. If the pump accelerates quickly or starts running too fast, stop it immediately and check the fluid supply. If the supply container is empty or air has been pumped into the lines, refill the container; prime the pump and the lines with fluid, or flush and leave it filled with a compatible solvent. Be sure to eliminate all air from the fluid system.

Do not attempt to operate pump unless it is securely mounted in a drum.

Daily Shutdown

1. Disconnect the air line quick disconnect coupler (55).
2. When air pressure is bled off, close the air needle valve (54).

Corrosion Protection for Pump

Caution

Water or moist air can cause your pump to corrode. To help prevent corrosion, NEVER leave the pump filled with water or air. After normal flushing, flush the pump again with mineral spirits solvent (also called white spirit) or oil-based solvent, relieve pressure, and leave the mineral spirits solvent (also called white spirit) in the pump. Be sure to follow to the **Pressure Relief Procedure** on page 13.

Lubrication

If you are not using an accessory air line lubricator, manually lubricate the motor daily. Disconnect the air regulator, place about 15 drops of light machine oil in the pump air inlet, reconnect the regulator and turn on the air supply to dispense oil into the motor.

Repair

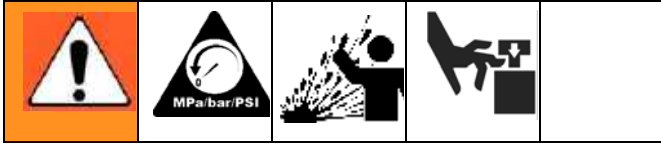

Before you start

- Have all the necessary repair parts on hand.
- Clean all parts with a compatible solvent. Inspect parts for wear or damage and replace as needed.
- Flush the pump, if possible. Stop the pump at the bottom of its stroke. Follow **Pressure Relief Procedure** on page 13 before repairing any part of the system.
- Disconnect the air and the fluid hoses and the grounding wire. Remove the pump from its mounting and clamp it in a vise.

Required Tools

- Pliers
- Set of socket wrenches
- Set of adjustable wrenches
- Insert Tool 24B917

Air Motor Disassembly

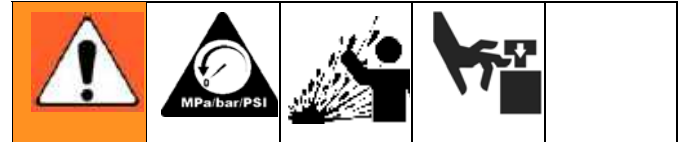

To reduce the risk of injury when servicing the air motor, always remove cylinder cap (34) from air cylinder (8) before removing air cylinder from base (13).

1. Unscrew the cylinder cap (34) from the cylinder (8). To remove the spring (7), pry gently under the coils in the direction of the helix. Inspect the spring (7) and gasket (27) for wear or damage; replace if necessary. See FIG. 10.

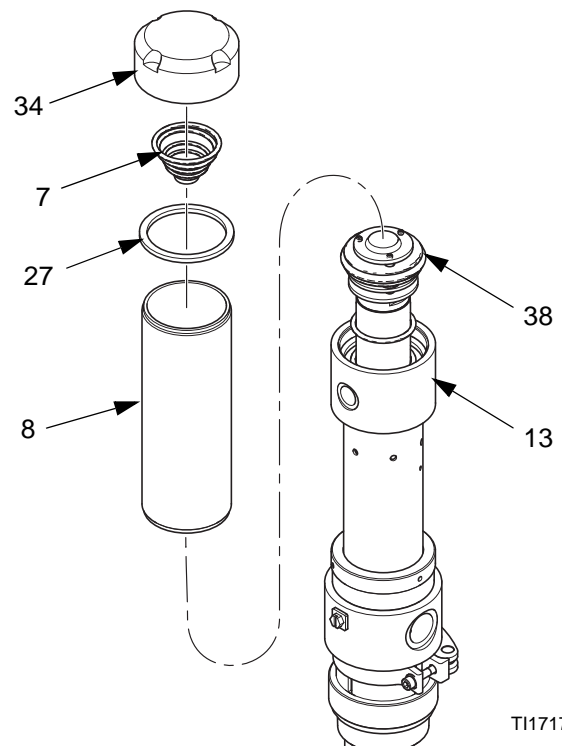

FIG. 10

2. Unscrew the cylinder (8) from the air motor base (13) and lift the cylinder straight off the air piston (38). Unscrew by hand or use a chain wrench to prevent distortion of the cylinder's shape. See FIG. 10.

- Use a pliers on the top plate of the air valve piston (38) and a wrench on the piston rod (35) to unscrew the air valve piston from the piston rod. See FIG. 11.

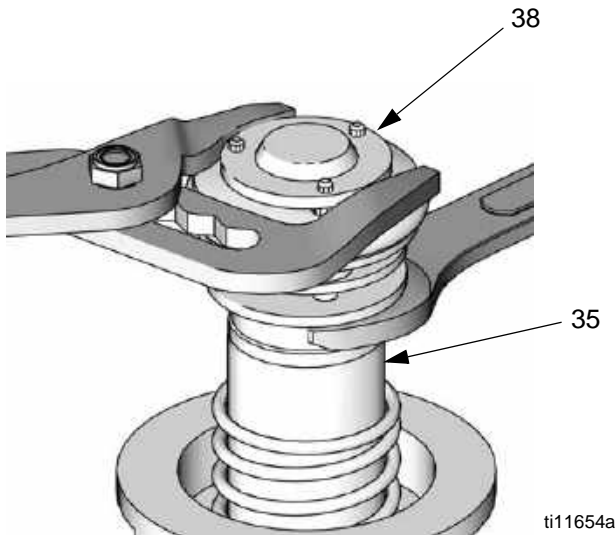

FIG. 11

- Remove washer (10), lower spring (9), and gasket (27). Inspect for wear or damage and replace as necessary. See FIG. 13.
- If any valve plate spacers (38d) are damaged, replace all three to maintain the correct clearance between the valve plates (18a,18f) and the seats. See FIG. 12.

① Apply locking compound to threads.

② Torque to 10-14 in-lb (1.1-1.6 N•m)

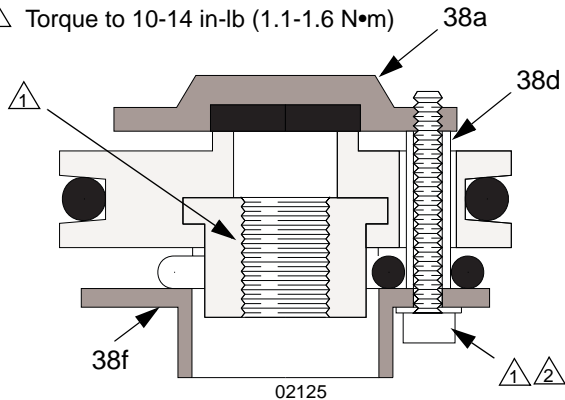

FIG. 12

- Disconnect the piston rod (35) from the pump connecting rod (37) and pull the piston rod out of the air motor base (13). Remove o-ring (6). Inspect o-ring (6) and replace if necessary.

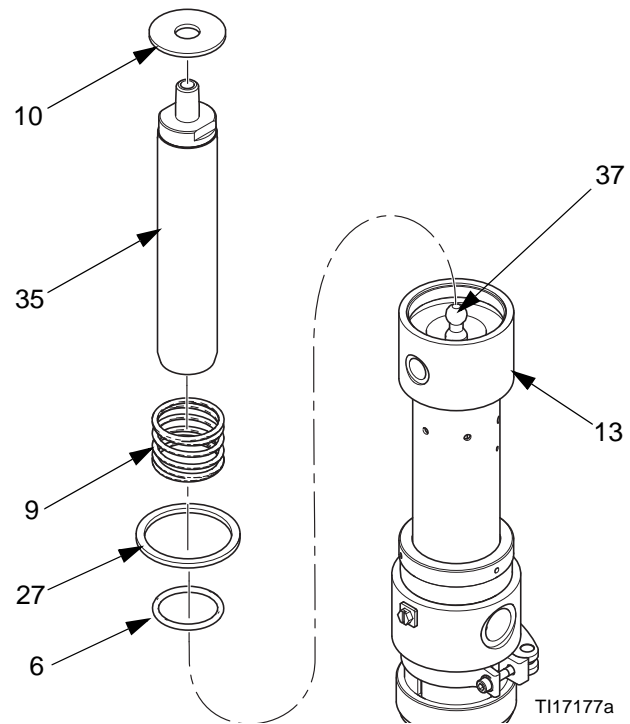

FIG. 13

Air Motor Reassembly

- Reinstall o-ring (6). Reconnect the piston rod (35) and the pump connecting rod (37). See FIG. 13.
- Reinstall the gasket (11), spring (9), and washer (10). Reassemble the piston (38). Apply thread sealant to the threads of the piston rod (35) and carefully screw the piston (38) onto the rod. See FIG. 11 and FIG. 13.



When installed, there should be 0.032 in. (0.8 mm) minimum clearance between the washer (10) and the shoulder of the piston rod (35).

3. Reinstall the spring (7) and gasket (27) on the cylinder cap (34) and screw the cap onto the cylinder (8). Screw the cylinder into the air motor base (13). See FIG. 10.

Pump Lower Disassembly



In mid-2013 the fluid section was upgraded to prevent threaded joints from loosening due to vibrations. Wrench flats were also added to improve serviceability.

Series A and B pumps can be upgraded with repair kit 24R989.

1. Unscrew the air motor connecting ring (15). Lay the pump on its side and rotate until the ball on the pump connecting rod (37) releases from the socket in the motor piston rod (35). Separate the motor from the displacement pump.

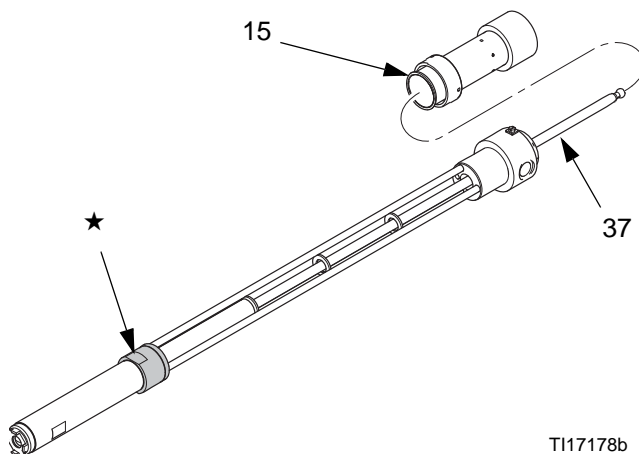

★ Support the Series A, B, and D pump frame with a strap wrench. Series C pumps have wrench flats.

FIG. 14



To repair the air motor, see **Air Motor Disassembly** on page 15.

2. Unscrew the intake valve housing (29) from the piston cylinder (58). Disassemble intake valve.

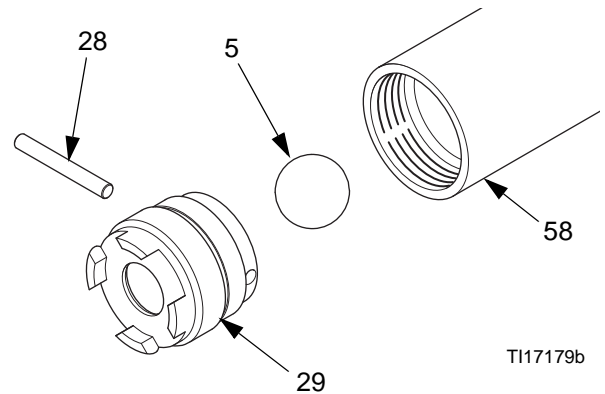
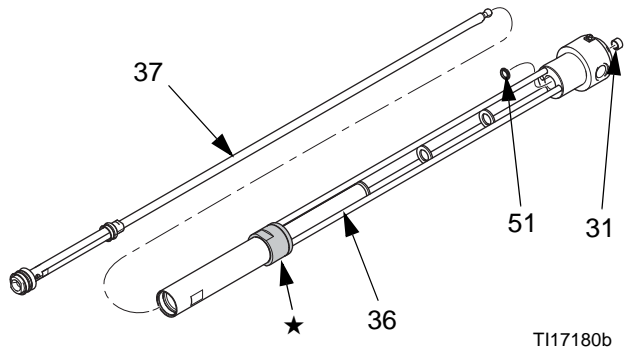

FIG. 15

3. Unscrew the piston cylinder (58) from the pump frame (36).

4. Push down on the pump connecting rod (37) until fluid piston assembly is clear of displacement pump frame (36). Pull the piston assembly and connecting rod out of the frame. Remove the bearing (31) and seal (51) from the frame.



★ Support the Series A, B, and D pump frame with a strap wrench. Series C pumps have wrench flats.

FIG. 16



Scoring or irregular surfaces on the connecting rods (37, 19) or polished inner wall of the pump frame (36) and piston cylinder (58) can cause premature packing wear and leaking. To check these parts, rub a finger over the surface or hold the part up to the light at an angle. Replace if necessary.

5. Unscrew the piston body (23) from the piston valve housing on the fluid piston rod (19).

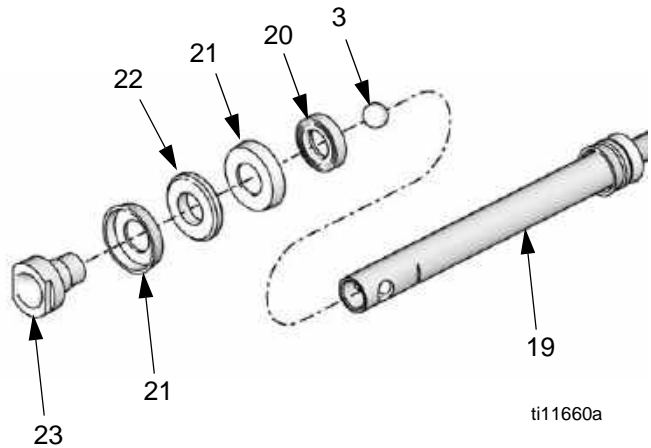

FIG. 17

6. Unscrew the fluid piston rod (19) from the pump connecting rod (37). Remove the cup packing (17) and bearing (18).

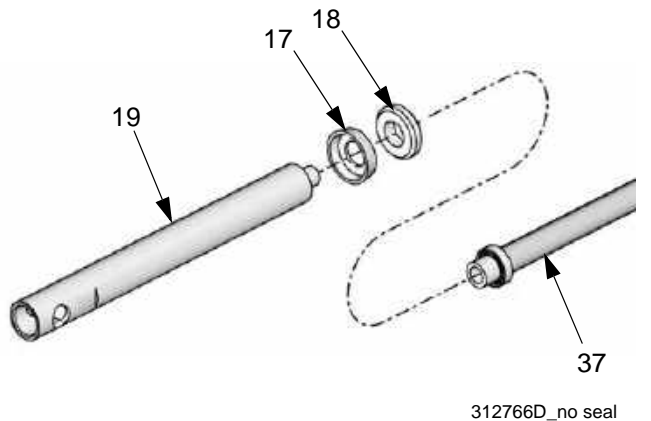

FIG. 18

Pump Lower Reassembly

1. Lubricate packing (17) and bearing (18) with no. 2 lithium-based grease.
2. Install the bearing (18), and cup packing (17) with the lips facing down on the pump connecting rod (37). See FIG. 18.
3. Lubricate the piston seals (21) and bearing (22) with no. 2 lithium-based grease. Install one piston seal (21) with the lips facing down, bearing (22), and second piston seal (21) with lips facing up on the piston (23). Install the backup washer (20) with the grooves facing down. See FIG. 17 on page 18.
4. Place the ball (3) on top of the piston body (23) and screw the piston body and the fluid piston rod (19) together. Torque to 30-35 ft-lb (41-48 N•m). Screw the piston valve housing (29) onto the lower connecting rod (19). See FIG. 17 on page 18.
5. Install the seal (51), with the lips facing down, in the displacement pump frame (36), then install bearing (31).

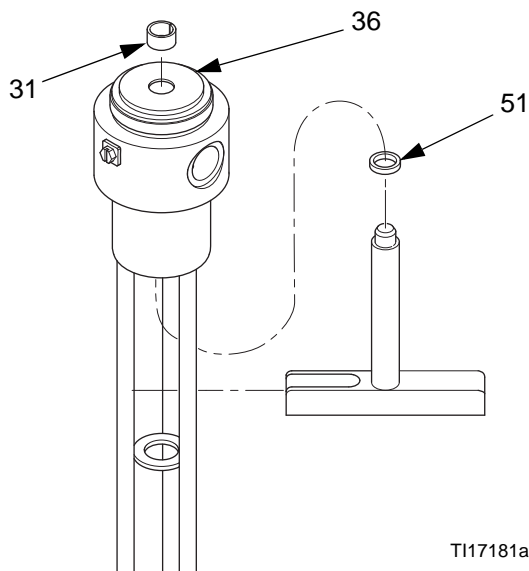

FIG. 19



Install seal (51) from the bottom of the pump frame (36) with insert tool 24B917.

6. Use a turning motion to maneuver and install the pump connecting rod (37) and piston back into the pump frame (36). See FIG. 14 on page 17.
7. Install piston cylinder (58).
 - a. *For Series A and B Pumps:* Support the pump frame (36) with a strap wrench. Lubricate o-ring (57) lightly with grease and apply loctite to threads of pump cylinder (58). Torque to 10-15 ft-lbs (13.5-20 N•m).

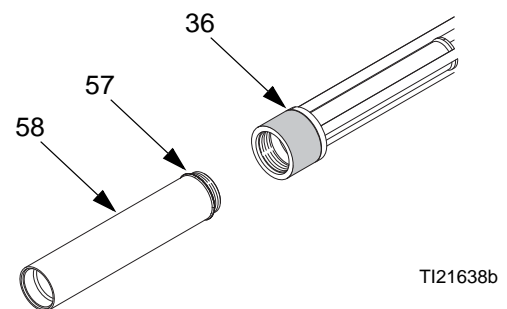

FIG. 20: Series A and B

- b. *For Series C Pumps:* Support the pump frame (36) with wrench flats. Lubricate o-ring (57) lightly with grease and apply loctite to threads of pump cylinder (58). Torque to 30-35 ft-lbs (41-48 N•m).

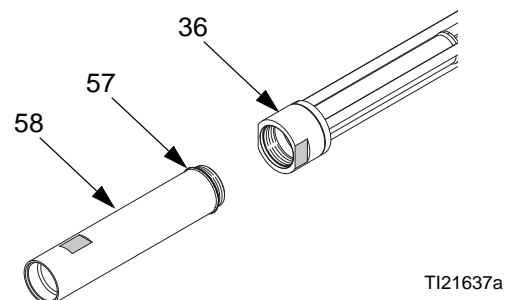

FIG. 21: Series C

- c. *For Series D Pumps:* Support the pump frame (36) with a strap wrench. Lubricate o-ring (57) lightly with grease and apply loctite to threads of pump cylinder (58). Torque to 30-35 ft-lbs (41-48 N•m).

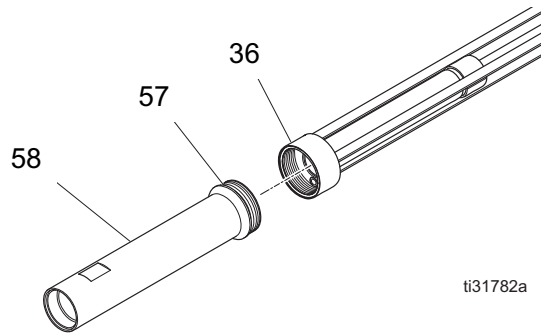

FIG. 22: Series D

- b. *For Series C and D Pumps:* Lubricate o-ring (59) and install thread locking compound to threads of intake valve (29). Torque to 30-35 ft-lbs (41-48 N•m).

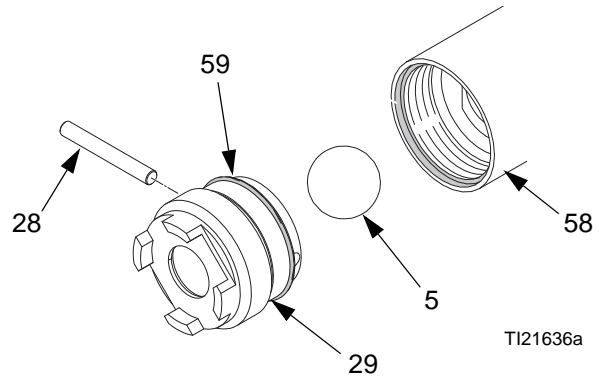

FIG. 24: Series C

8. Install intake valve (29).

- a. *For Series A and B Pumps:* Apply thread locker to threads of intake valve (29). Torque to 10-15 ft-lbs (13.5-20 N•m).

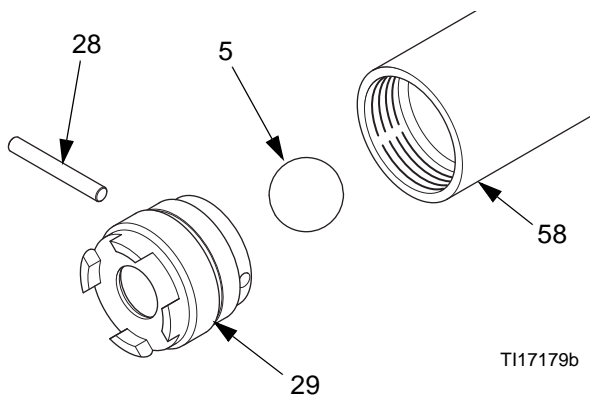

FIG. 23: Series A and B

Troubleshooting

Problem	Cause	Solution
The pump fails to operate.	Dirty or worn air motor.	Clean, service.
	Inadequate air supply or restricted lines.	Clean lines or increase the air supply (see Technical Data).
	Closed or clogged air valves.	Open or clear the valves.
	Clogged fluid hose or valve.	Clear the hose or valves.
	Worn or damaged valves or seals.	Service the valves or seals.
The pump operates, but the output is low on both strokes.	Clogged fluid hose or valve.	Clear the hose or valves.
	Low or empty fluid supply.	Refill the fluid supply and re-prime the pump.
	Worn or damaged valves or seals.	Service the valves or seals.
The pump operates, but the output is low on the down-stroke.	Held open or worn intake valve.	Clear or service the valve.
	Worn or damaged valves or seals.	Service the valves or seals.
The pump operates, but the output is low on the upstroke.	Held open or worn piston valve.	Clear or service the valve.
	Worn or damaged valves or seals.	Service the valves or seals.
Erratic or accelerated operation.	Low or empty fluid supply.	Refill the fluid supply and re-prime the pump.
	Broken air motor compression spring.	Replace the spring.
Pump slowly moves after fluid shutoff in downstroke.	Clogged or dirty intake valve check ball.	Clean ball and seat.
	Worn or damaged valves or seats.	Install repair kit.
Pump slowly moves after fluid shutoff in upstroke.	Clogged or dirty lower piston ball or seat.	Clean ball and seat.
	Worn or damaged valves or seats.	Install repair kit.

Parts

T1 2:1 Ratio Transfer Pump, 256200

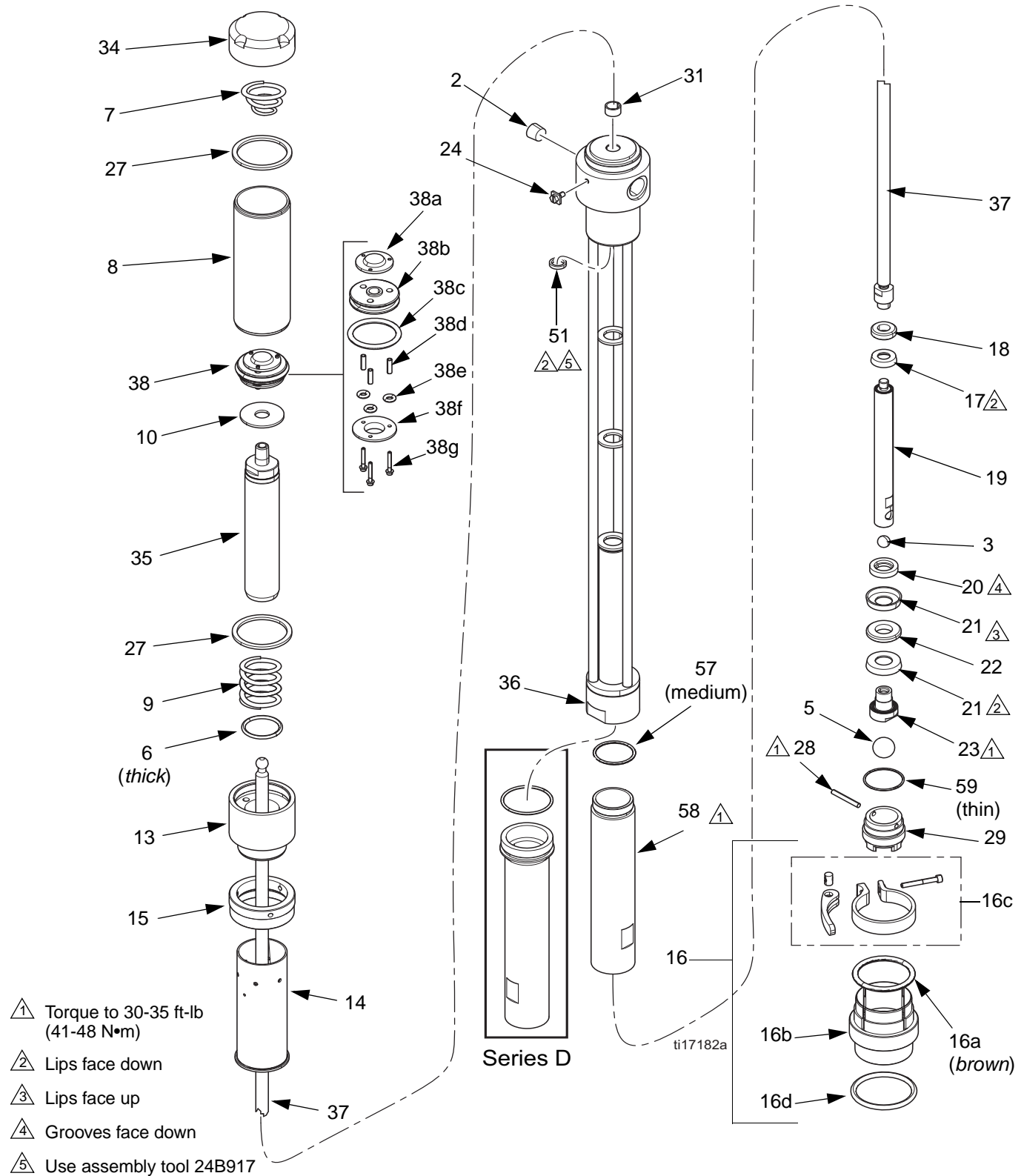

T1 2:1 Ratio Transfer Pump, 256200

Ref.	Part	Description	Qty.	Ref.	Part	Description	Qty.
2	101748	PLUG, pipe; SST	1	36	24K361	FRAME, pump	1
3◆	101750	BALL, bearing, upper	1	37	256431	ROD, pump, connector	1
5◆	101917	BALL, bearing, lower	1	38	24J679	PISTON, valve, air	1
6†	156698	O-RING	1	38a†	162729	PLATE, exhaust	1
7†	157630	SPRING, compression, tapered	1	38b	189210	PISTON	1
8	24J673	CYLINDER, air	1	38c†	108357	O-RING	1
9†	157633	SPRING, compression	1	38d	181485	SPACER	3
10	157872	WASHER, valve	1	38e†	108358	O-RING	3
13	24J674	BASE, motor, air	1	38f	181487	PLATE, intake	1
14	24J675	HOUSING, connecting rod	1	38g	220884	SCREW, #6-32	3
15	24J676	RING, connecting	1	39	172479	TAG, instruction	1
16	253146	ADAPTER, bung; SST (includes 16a-16g)	1	51◆	111791	SEAL	1
16a◆	120207	O-RING; inner	1	54✖	206264	VALVE, needle	1
16b	24J526	ADAPTER	1	55✖	169969	FITTING, line, air	1
16c	234188	CLAMP, hopper	1	56✖	114558	COUPLER, line, air	1
16d◆	120998	O-RING; O.D.	1	57★	131227	O-RING (Series D)	1
17◆	161788	PACKING, cup; upper piston	1		118403	O-RING (Series A, B, and C)	1
18◆	16C799	BEARING, piston, upper	1	58★	26C049	CYLINDER, piston (Series D)	1
19	256432	ROD, piston, fluid	1		24R988	CYLINDER, piston (Series A, B, and C)	1
20	161792	RING, back-up	1	59★	103414	O-RING	1
21◆	161793	SEAL, piston, lower	2				
22◆	186648	BEARING, piston, lower	1				
23	161795	PISTON	1				
24	116343	SCREW, ground	1				
25✖	15K008	LABEL, ID	1				
27†	162989	GASKET	2				
28	164250	PIN, ball stop	1				
29★	24T262	HOUSING, valve, intake	1				
31◆	166564	BEARING, connecting rod	1				
34	256429	CAP, cylinder, air	1				
35	24J678	ROD, piston	1				

Complete T1 pump repair kit 24X055 contains repair kits 247958 and 24K363.

† *Parts included in repair kit 247958.*

◆ *Parts included in repair kit 24K363.*

✖ *Indicates parts not shown (shipped loose).*

★ *Parts included in repair kit 24R989. See **Pump Lower Disassembly**, page 17, for instructions.*

Accessories

Grounding Clamp

Part	Description	Qty.
103538	CLAMP, ground	1

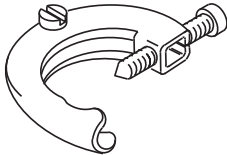

Part	Description	Qty.
214848	LUBRICATOR, air line; 8 oz (0.24 liter) bowl capacity; 1/2 npt(f) inlet and outlet	1

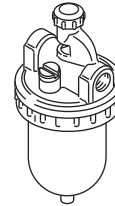

Bleed-Type Master Air Valve

300 psi (2.1 MPa, 21 bar) Maximum Working Pressure

Part	Description	Qty.
107142	VALVE, ball, vented; 1/2 npt(m) inlet x 1/2 npt(f) outlet	1

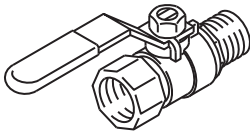

Air Line Filter and Regulator

180 psi (1.3 MPa, 13 bar) Maximum Working Pressure

Part	Description	Qty.
202660	FILTER, air; includes gauge and two 1/4 npt(m) outlet valves, 50 micron filter element with 100 mesh inlet strainer; 1/2 npt(f) inlet; flow rate is over 50 scfm (1.4 m ³ /min).	1

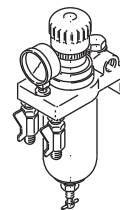

01355

Air Line Filter

250 psi (1.7 MPa, 17.5 bar) Maximum Working Pressure

Part	Description	Qty.
106149	FILTER, air line; 1/2 npt(f) inlet and outlet	1

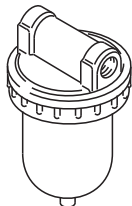

Air Line Lubricator

250 psi (1.7 MPa, 17.5 bar) Maximum Working Pressure

Air Regulator and Gauge

300 psi (2.1 MPa, 21 bar) Maximum Working Pressure

Part	Description	Qty.
202156	REGULATOR, air; 0-200 psi (0-14 bar) regulated pressure range; 3/8 npt(f) inlet and outlet	1

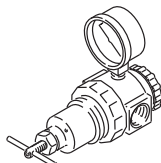

Fluid Drain Valve

500 psi (3.5 MPa, 35 bar) Maximum Working Pressure

Part	Description	Qty.
208630	VALVE, ball; 1/2 npt(m) x 3/8 npt(f); for non-corrosive fluids; carbon steel and PTFE	1
237534	VALVE, ball; 3/8 npt(m) x 3/8 npt(f); for corrosive fluids; SST and PTFE	1

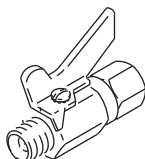

Insert Tool 24B917 (4 in. long)

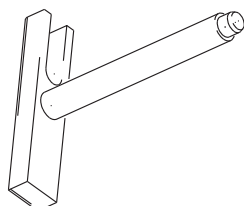

01357

Fluid Pressure Regulator

250 psi (1.7 MPa, 17.5 bar) Maximum Working Pressure

Part	Description	Qty.
203831	REGULATOR, fluid; carbon steel; 0-60 psi (0-4 bar) regulated fluid pressure range; 2 gpm (7.6 liter/min) maximum flow rate	1
209030	REGULATOR, fluid; stainless steel; 5-100 psi (0.4-7 bar) regulated fluid pressure range; 3 gpm (11.3 liter/min) maximum flow rate	1

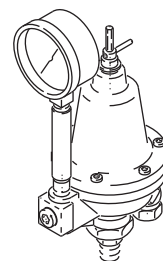

01356

Fluid Filter

300 psi (2.1 MPa, 21 bar) Maximum Working Pressure

Part	Description	Qty.
213057	FILTER, 30 mesh	1
213058	FILTER, 60 mesh	1
213059	FILTER, 100 mesh	1

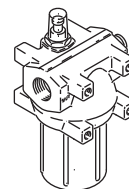

0779

UHMWPE Packing Conversion Kit, 224017

Part	Description	Qty.
111004	PACKING, cup	2
111005	PACKING, cup	2
161789	BEARING, piston	1
161794	BEARING, piston	1
405977	MANUAL, instruction	1

Dimensions

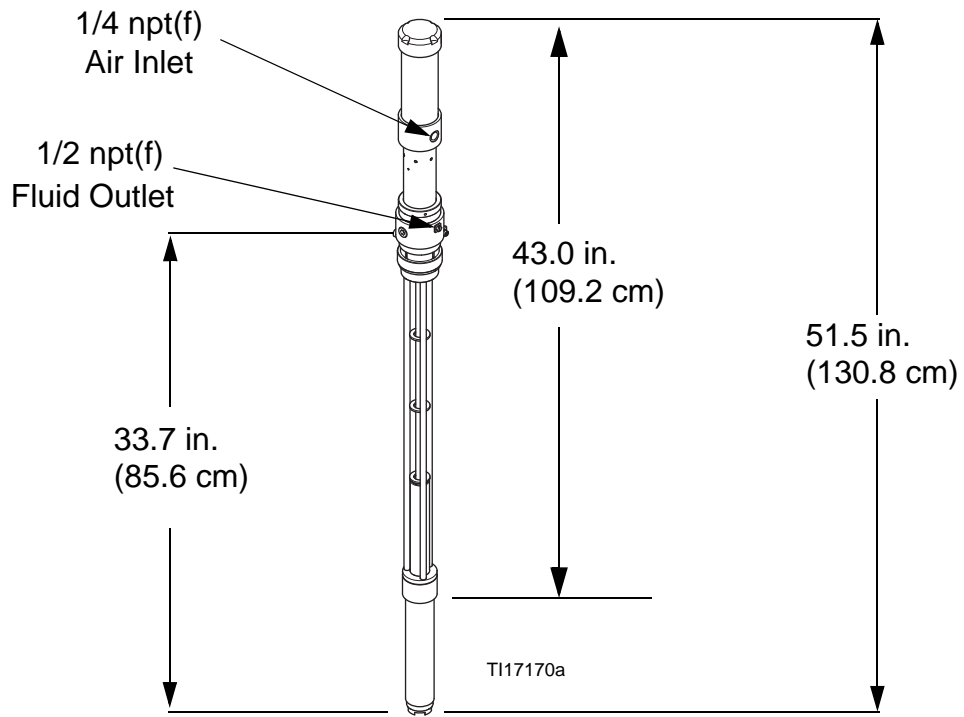

Technical Data

Pressure ratio	2:1
Maximum fluid working pressure	360 psi (2.5 MPa, 25 bar)
Maximum air inlet pressure	180 psi (1.2 MPa, 12 bar)
Pump cycles per 1 gallon (3.8 liters)	40
Maximum recommended pump speed for continuous operation	100 cycles per min (150 cycles per min intermittent)
Gallons (liters) per pump cycle	0.025 (0.095)
Air consumption	See Performance Chart on page 28.
Maximum ambient temperature	120° F (50° C)
Maximum fluid temperature	180° F (82° C)
Wetted parts	Stainless Steel, PTFE, PEEK
Fluid recirculation port	3/8 npt(f)
Air inlet port	1/4 npt(f)
Fluid outlet port	1/2 npt(f)
Weight	18.5 lbs. (8.4 kg)
Sound Pressure	88.7 dB(A) at 80 psi (0.55 MPa, 5.5 bar)
Sound Power, per ISO 9614-2	96.8 dB(A) at 80 psi (0.55 MPa, 5.5 bar)

Performance Chart

Calculate Fluid Outlet Pressure (black curves)

To calculate fluid outlet pressure (MPa/bar/psi) at a specific fluid flow (lpm/gpm) and operating air pressure (MPa/bar/psi), use the following instructions and pump data chart.

1. Locate desired fluid flow along bottom of chart.
2. Follow vertical line up to intersection with selected air pressure curve (black). Follow horizontally left to read fluid outlet pressure.

Calculate Pump Air Consumption (gray curves)

To calculate pump air consumption (m³/min or scfm) at a specific fluid flow (lpm/gpm) and air pressure (MPa/bar/psi), use the following instructions and pump data chart.

1. Locate desired fluid flow along bottom of chart.
2. Follow vertical line up to intersection with selected air pressure curve (gray). Follow horizontally right to read air consumption.

Key:

- A 180 psi (1.2 MPA, 12.4 bar)
- B 100 psi (0.7 MPA, 7 bar)
- C 70 psi (0.5 MPA, 7.8 bar)
- D 40 psi (0.3 MPA, 2.8 bar)

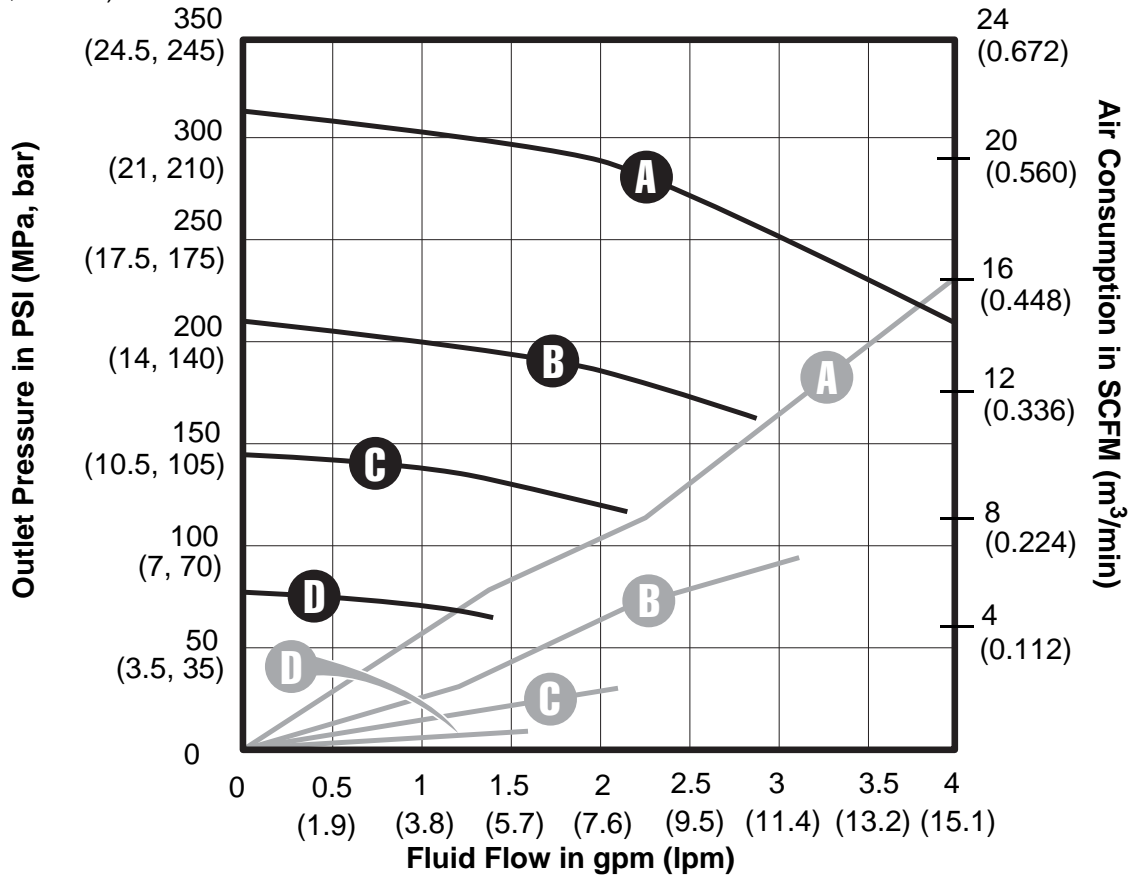

Graco Standard Warranty

Graco warrants all equipment referenced in this document which is manufactured by Graco and bearing its name to be free from defects in material and workmanship on the date of sale to the original purchaser for use. With the exception of any special, extended, or limited warranty published by Graco, Graco will, for a period of twelve months from the date of sale, repair or replace any part of the equipment determined by Graco to be defective. This warranty applies only when the equipment is installed, operated and maintained in accordance with Graco's written recommendations.

This warranty does not cover, and Graco shall not be liable for general wear and tear, or any malfunction, damage or wear caused by faulty installation, misapplication, abrasion, corrosion, inadequate or improper maintenance, negligence, accident, tampering, or substitution of non-Graco component parts. Nor shall Graco be liable for malfunction, damage or wear caused by the incompatibility of Graco equipment with structures, accessories, equipment or materials not supplied by Graco, or the improper design, manufacture, installation, operation or maintenance of structures, accessories, equipment or materials not supplied by Graco.

This warranty is conditioned upon the prepaid return of the equipment claimed to be defective to an authorized Graco distributor for verification of the claimed defect. If the claimed defect is verified, Graco will repair or replace free of charge any defective parts. The equipment will be returned to the original purchaser transportation prepaid. If inspection of the equipment does not disclose any defect in material or workmanship, repairs will be made at a reasonable charge, which charges may include the costs of parts, labor, and transportation.

THIS WARRANTY IS EXCLUSIVE, AND IS IN LIEU OF ANY OTHER WARRANTIES, EXPRESS OR IMPLIED, INCLUDING BUT NOT LIMITED TO WARRANTY OF MERCHANTABILITY OR WARRANTY OF FITNESS FOR A PARTICULAR PURPOSE.

Graco's sole obligation and buyer's sole remedy for any breach of warranty shall be as set forth above. The buyer agrees that no other remedy (including, but not limited to, incidental or consequential damages for lost profits, lost sales, injury to person or property, or any other incidental or consequential loss) shall be available. Any action for breach of warranty must be brought within two (2) years of the date of sale.

GRACO MAKES NO WARRANTY, AND DISCLAIMS ALL IMPLIED WARRANTIES OF MERCHANTABILITY AND FITNESS FOR A PARTICULAR PURPOSE, IN CONNECTION WITH ACCESSORIES, EQUIPMENT, MATERIALS OR COMPONENTS SOLD BUT NOT MANUFACTURED BY GRACO. These items sold, but not manufactured by Graco (such as electric motors, switches, hose, etc.), are subject to the warranty, if any, of their manufacturer. Graco will provide purchaser with reasonable assistance in making any claim for breach of these warranties.

In no event will Graco be liable for indirect, incidental, special or consequential damages resulting from Graco supplying equipment hereunder, or the furnishing, performance, or use of any products or other goods sold hereto, whether due to a breach of contract, breach of warranty, the negligence of Graco, or otherwise.

FOR GRACO CANADA CUSTOMERS

The Parties acknowledge that they have required that the present document, as well as all documents, notices and legal proceedings entered into, given or instituted pursuant hereto or relating directly or indirectly hereto, be drawn up in English. Les parties reconnaissent avoir convenu que la rédaction du présente document sera en Anglais, ainsi que tous documents, avis et procédures judiciaires exécutés, donnés ou intentés, à la suite de ou en rapport, directement ou indirectement, avec les procédures concernées.

Graco Information

For the latest information about Graco products, visit www.graco.com.

TO PLACE AN ORDER, contact your Graco distributor or call to identify the nearest distributor.

Phone: 612-623-6921 **or Toll Free:** 1-800-328-0211 **Fax:** 612-378-3505

All written and visual data contained in this document reflects the latest product information available at the time of publication. Graco reserves the right to make changes at any time without notice.

For patent information, see www.graco.com/patents.

Original instructions. This manual contains English. MM 312766

Graco Headquarters: Minneapolis

International Offices: Belgium, China, Japan, Korea

GRACO INC. AND SUBSIDIARIES • P.O. BOX 1441 • MINNEAPOLIS MN 55440-1441 • USA
Copyright 2008, Graco Inc. All Graco manufacturing locations are registered to ISO 9001.

www.graco.com

Revision P, July 2017